



PRODUCT

USE INSTRUCTIONS



[Technical support]

Ordering code: 007B11

Part number: FNI MPL-508-105-M

FNI MPL-508-105-M

8xIO-Link,16 DI/DO PNP

IO-Link master module user manual

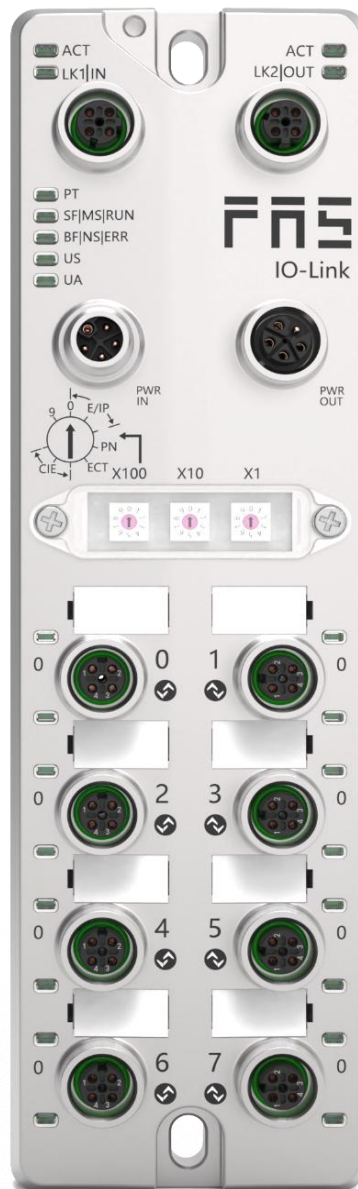

Contents

Security	5
■ Expected use	5
■ Installation and start-up	5
■ Corrosion resistance	5
■ Dangerous voltage	5
■ General security	6
1 Getting started guide	7
1.1 Module overview	7
1.2 Mechanical connection	8
1.3 Electrical connections	8
1.3.1 Power interface (L-code)	8
1.3.2 Network interface (D-code)	9
1.3.3 I/O-port (A-code)	9
1.3.4 Master module wiring method	9
2 Technical data	11
2.1 Size	11
2.2 Mechanical data	11
2.3 Operating conditions	11
2.4 Electrical data	11
2.5 Network port	12
2.6 Function indicator	12
3 Integrated	16
3.1 Module configuration	16
3.1.1 Restore factory settings and switch communication protocols	16
3.1.2 Network segment modification (only applicable to EIP, CCIEBS, Modbus TCP communication protocols)	17
3.1.3 CCIEBS setting the number of occupied stations	18
3.2 Data mapping	18
3.3 PLC integration tutorial	30
3.3.1 Siemens S7-1200 Botu Integration (PN)	30
3.3.2 Omron NX1P2 Sysmac Studio Integrated (EIP)	32
3.3.3 Mitsubishi FX5U Work2 Integrated (CIE)	34

3.4 Modbus TCP communication configuration	36
3.4.1 Integrated in Inovance Autoshop	36
3.4.2 Integrated in Siemens Portal	39
4 Appendix	45
4.1 Materials included	45
4.2 Order code	45
4.3 Ordering information	45

Security

■ Expected use

This manual describes as decentralized input and output modules for connecting to an industrial network.

■ Installation and start-up

Precautions!

Installation and start-up may only be performed by trained personnel. A qualified individual is one who is familiar with the installation and operation of the product and has the necessary qualifications to perform such operations. Any damage caused by unauthorized operation or illegal and improper use is not covered by the manufacturer's warranty. The equipment operator is responsible for ensuring that appropriate safety and accident prevention regulations are observed.

■ Corrosion resistance

Precautions!

FNI modules generally have good chemical and oil resistance. When used in corrosive media (e.g. high concentrations of chemicals, oils, lubricants, coolants and other material media (i.e. very low water content), these media must be checked before the corresponding application material compatibility. If a module fails or is damaged due to this corrosive medium, a defect claim cannot be made.

■ Dangerous voltage

Precautions!

Disconnect all power before using the device!

■ General security

Debugging and inspection	Fault	Owner/operator obligations	Expected use
<p>Before debugging, read the user manual carefully.</p>	<p>If the defect or equipment failure cannot be corrected, the operation of the equipment must be stopped to avoid damage that may be caused by unauthorized use.</p>	<p>This equipment is an EMC Class A compliant product. This device produces RF noise.</p>	<p>The warranty and limited liability statement provided by the manufacturer does not cover damage caused by:</p> <ul style="list-style-type: none"> ·Unauthorized tampering ·Improper use operation <p>·The instructions provided in the user manual explain the use, installation and handling of discrepancies</p>
<p>This system cannot be used in an environment where the safety of personnel depends on the functionality of the equipment.</p>	<p>Only after the housing is fully installed can the intended use be assured.</p>	<p>The owner/operator must take appropriate precautions to use this equipment.</p> <p>This device can only use the power supply that matches this device, and can only connect cables approved for application.</p>	

1. Getting Started Guide

1.1 Module overview

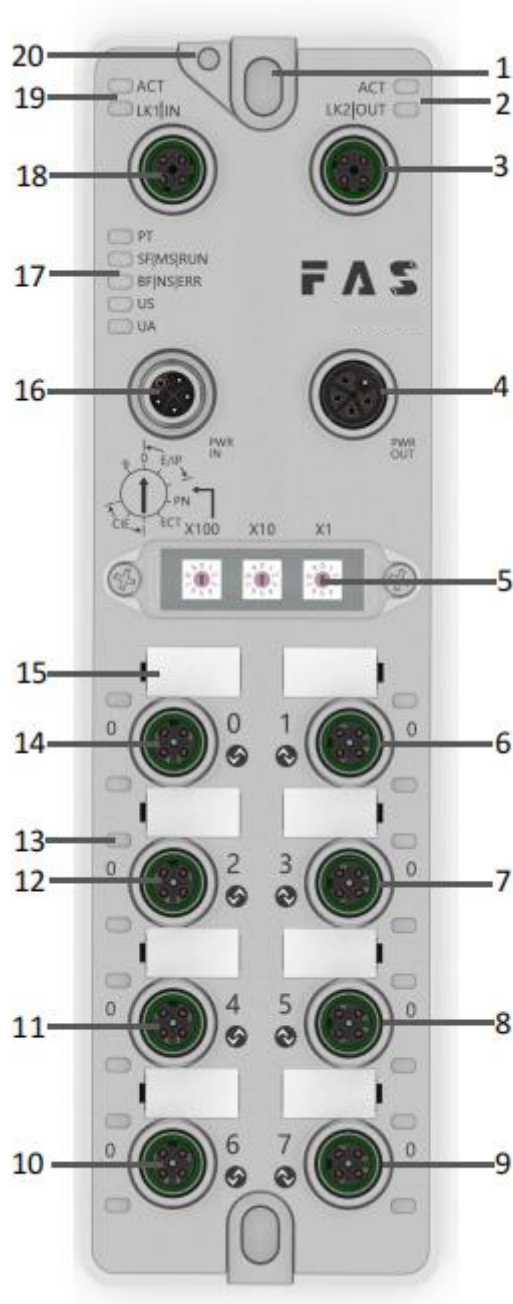

- | | | |
|-----------------------------------|--------------------------|------------------------------------|
| 1 Mounting hole | 8 Port 5 | 15 Port identification plate |
| 2 Network port 2 status indicator | 9 Port 7 | 16 Power input port |
| 3 Network port 2 | 10 Port 6 | 17 Module indicator light |
| 4 Power output port | 11 Port 4 | 18 Network port 1 |
| 5 DIP switch | 12 Port 2 | 19 Network port 1 status indicator |
| 6 Port 1 | 13 Port status indicator | 20 Ground connection |
| 7 port 3 | 14 port 0 | |

1.2 Mechanical connection

The modules are connected using 2 M6 bolts and 2 washers.
Isolation pads are available as accessories.

1.3 Electrical connection

1.3.1 Power interface (L-code)

Definition of power input port Definition of power output port



Power port

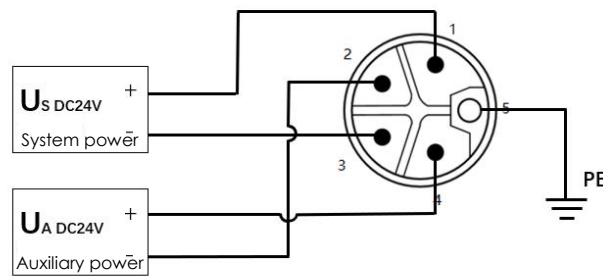

Pin	Function	Description
1	Us+	+24V(Brown)
2	Ua-*	0V(White)
3	Us-	0V(Blue)
4	Ua+*	+24V(Black)
FE	Functional ground*	FE (Yellow green)

Note:

1. If possible, provide sensor/module power supply and actuator power supply separately.
Total current <16A, even if the actuator power supply is daisy chained, the total current of all modules is <16A.
2. The FE connection from the housing to the machine must be low impedance and kept as short as possible.

1.3.2 Network interface (D-code)

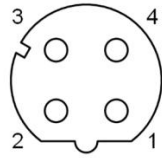

Pin	Function	
1	Tx+	Send data+
2	Rx+	Receive data+
3	Tx-	Send data-
4	Rx-	Receive data-

Note:

Unused I/O port sockets must be covered with end caps to meet IP67 protection rating.

1.3.3 I/O-port (A-code)

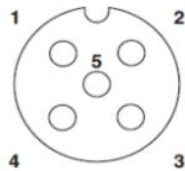

Pin	Function
1	+24V (Brown) maximum current 1A
2	Input /Output (White)
3	0V(Blue)
4	Input /Output/IOLINK(Black)
5	FE(Gray)

Normal I/O

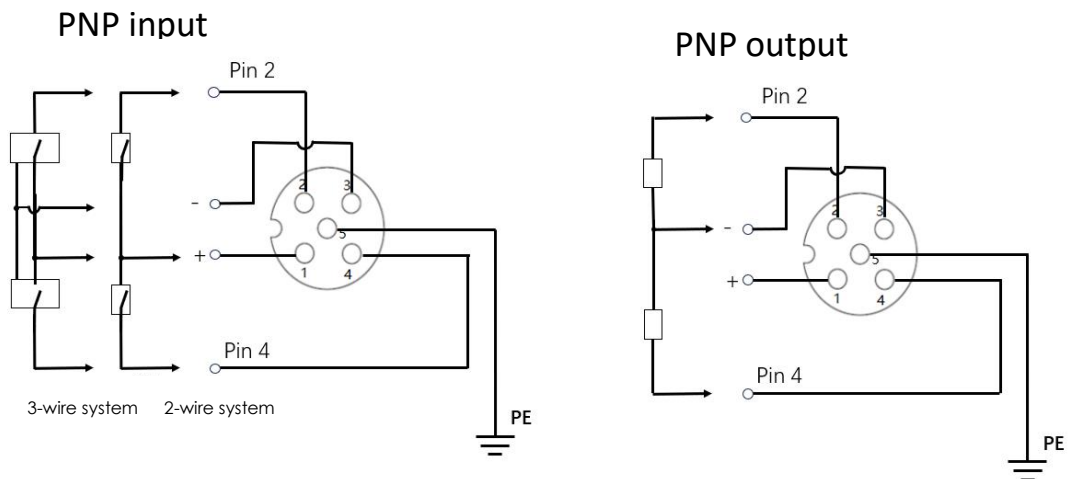

Note:

1. Regarding digital sensor input, please follow the input guidance of EN61131-2, Type 2.
2. The maximum output current of each port is 2A. The total module current is 16A.
3. Unused I/O port sockets must be covered with end caps to meet IP67 protection level.

1.3.4 Master module wiring method

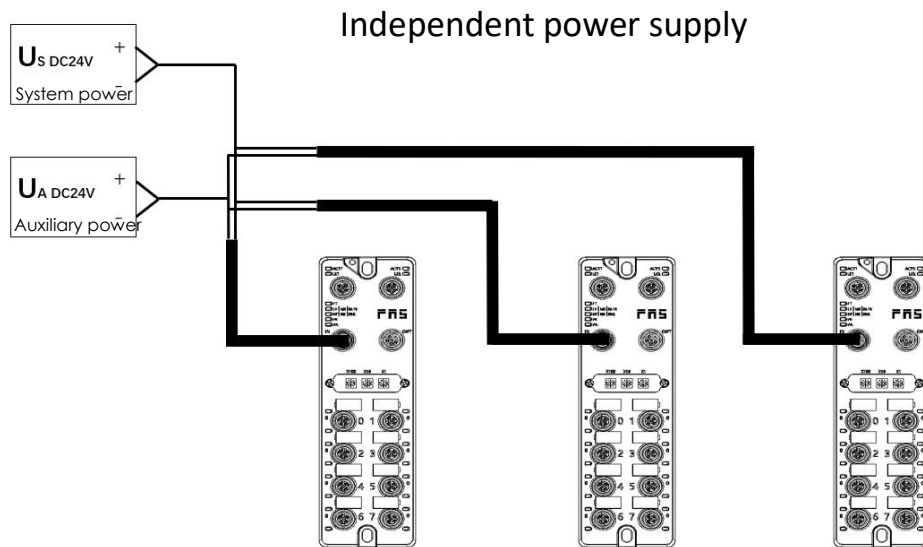

In independent power supply mode, the maximum current of each master station can reach 16A.

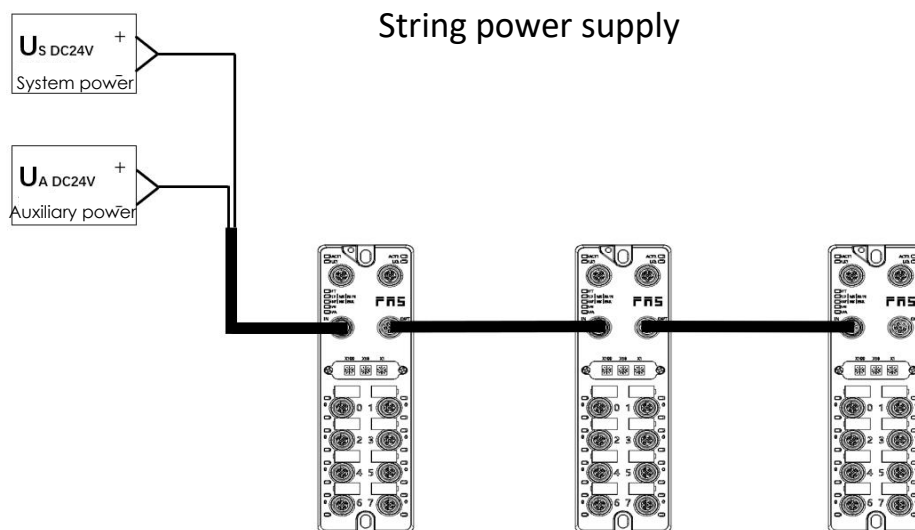

In the serial power supply wiring mode, if the rear module needs to be connected to the front module, the cumulative current must not exceed 16A.

2. Technical data

2.1 Size

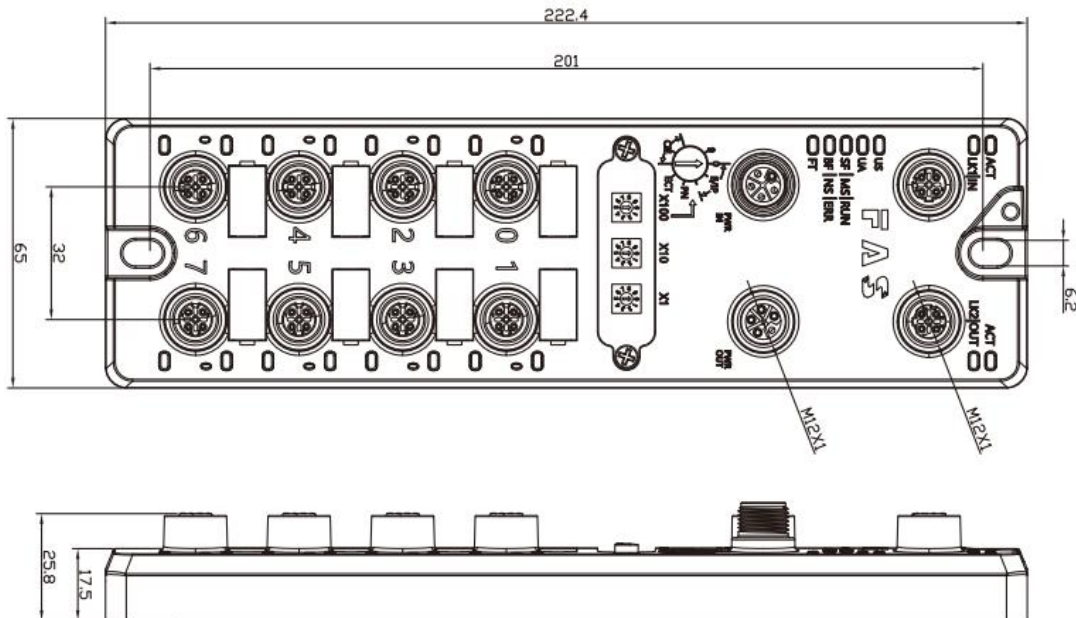

2.2 Mechanical data

Shell material	Die-cast aluminum housing, pearl nickel plated
Housing rating according to IEC 60529	IP67 (Only in plug-in or plug type)
Power interface	L-Code (male and female)
Input port/output port	M12, A-Code (8*Female)
Size(W*H*D)	65mm*222mm*25.8mm
Installation type	2-Through hole mounting
Ground bus accessories	M4
Weight	About 670g

2.3 Operating conditions

Operating temperature	-5°C ~ 70°C
Storage temperature	-25°C ~ 70°C

2.4. Electrical data

Voltage	18~30V DC, conform to EN61131-2
Voltage fluctuation	<1%
Input current when power supply voltage is 24V	<130mA

2.5 Network port

Prt	2 x 10Base-/100Base-Tx
Port connection	M12, D-Code
IEEE 802.3 compliant cable types	Shielded twisted pair, minimum STP CAT 5/STP CAT 5e
Data transfer rate	10/100Mbit/s
Maximum cable length	100m
Flow control	Half working condition/full working condition (IEEE 802.3-PAUSE)

2.6 Function indicator



PT	Green	EtherNet/IP communication protocol
	Yellow	ProfiNet communication protocol
	Blue	EtherCat communication protocol (reserved)
	Ice blue	Modbus TCP communication protocol
	White	CC-Link IE Field basic communication protocol

EtherNet/IP communication protocol module status

LED	Show	Function
MS	Green light is always on	Working status: The equipment is running normally
	Green light flashes 1HZ	Standby: The device is not configured
	Flashing green, red and green alternately	Self-test: The device is undergoing a power-on self-test.
	Flashing red 1HZ	Recoverable faults:
	Red light always on	Unrecoverable failure
	Closure	US no input voltage
NS	Green light is always on	Connected
	Green light flashes 1HZ	Not connected
	Flashing green and red alternately	Self-test: The device is undergoing a power-on test.
	Red light flashes 1HZ	Connection timed out
	Red light always on	Duplicate IP
	Closure	USNo input voltage or no IP address

US	Green	Input voltage is normal
	Flashing red	Input voltage low (< 18 V)
UA	Green	Output voltage is normal
	Flashing red	Output voltage low (< 18 V)
	Red always on	No output voltage present (< 11 V)

Profinet communication protocol module status

LED	Show	Function
SF	Closure	Working fine
	Flashing red 3s 1HZ	Bus start
	Red always on	System error
BF	Closure	Working fine
	Flashing red 2HZ	No data exchange
	Red always on	No configuration; or low speed physical link; or no physical link
US	Green	Input voltage is normal
	Flashing red	Input voltage low (< 18 V)
UA	Green	Output voltage is normal
	Flashing red	Output voltage low (< 18 V)
	Red always on	No output voltage present (< 11 V)

CC-Link IE Field Basic communication protocol module status

LED	Show	Function
RUN	Green light off	Module not connected
	Green light flashes 2.5HZ	Module has no communication
	Green light flashes 10HZ	Module not configured
	Steady green	Running: The device is running
	Closure	Module disconnected
ERR	Closure	Module disconnected
	Red light always on	Communication error
	Red light flashing	Watchdog timeout
US	Green	Input voltage is normal
	Flashing red	Input voltage low (< 18 V)
UA	Green	Output voltage is normal
	Flashing red	Output voltage low (< 18 V)
	Red always on	No output voltage present (< 11 V)

Modbus TCP communication protocol module status

LED	Show	Function
RUN	Green light off	Module not connected
	Green light flashes 5HZ	Module configured
	Green light flashes 1HZ	Module is prepared but not configured
	Steady green	Running: The device has at least one TCP communication
	Closure	Module not ready
ERR	Closure	Module works fine
	Red light flashes (2HZ)	System error
	Red light always on	Communication error
US	Green	Input voltage is normal
	Flashing red	Input voltage low (< 18 V)
UA	Green	Output voltage is normal
	Flashing red	Output voltage low (< 18 V)
	Red always on	No output voltage present (< 11 V)

I/O port status

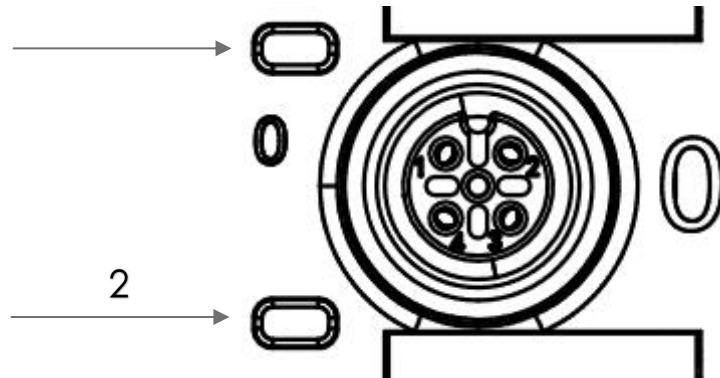

LED	State	Function
1	Closure	The status of Pin4 input or output is 0
1	Yellow	The status of Pin4 input or output is 1
1	Red	Port configured as output: Pin4 short circuit
1	Flashing red	Port configured as output: Pin1 short circuit
1	Green	IO-Link is connected
1	Flashing green	IO-Link not connected
2	Closure	The status of Pin2 input or output is 0
2	Yellow	The status of Pin2 input or output is 1
2	Red	The UA power supply is cut off or the network is disconnected or Pin2 is short-circuited.
2	Flashing red	Pin1 short circuit

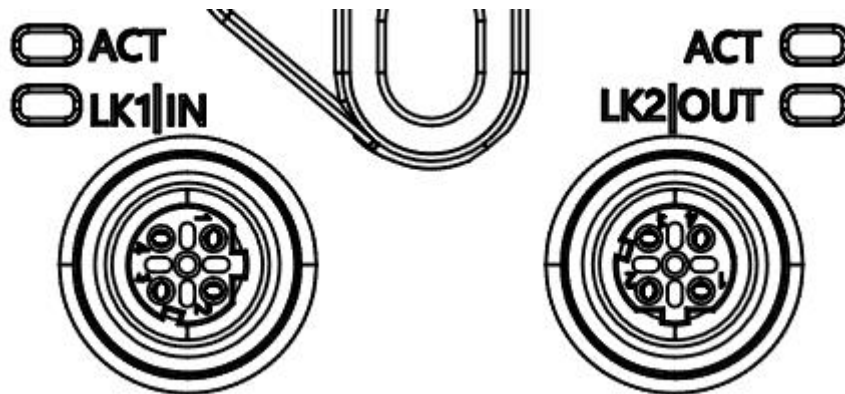

Network port status

LED	State	Function
ACT	Closure	Bus rate: 10Mbit/s
	Yellow	Bus rate: 100Mbit/s
LK1 IN (ECT IN)	Flashing green	Data transfer in progress
LK2 IN (ECT OUT)	Flashing green	Data transfer in progress

3.Integrated

3.1 Module configuration

3.1.1 Restoring factory settings and switching communication protocols

LED indicator light PT color indicates the current protocol

Serial number	X100	X10	X1	letter of agreement	PT
1	0~2	0~9	0~9	ETHERNET/IP	Green light
2	3	—	—	PROFINET	Orange light
3	4	—	—	ETHERCAT	Blue
4	5~7	0~9	0~9	CIEBS	White
5	8	0~9	0~9	Modbus TCP	Ice blue

Steps:

1. When the device is powered off, dial 900;
2. Power on the device and wait 5 seconds;
3. When the device is powered off, dial the code according to different protocols and the last digit of IP (can be set directly);
4. Power on the device and wait 30 seconds until the PF light turns to the corresponding protocol color;

In Modbus TCP mode: the IP address can be adjusted by dialing. When the dialing is 801, the address is 192.168.0.1. It can be adjusted by X10 and X1 dialing, and the range is 801-899.

3.1.2 Network segment modification (only applicable to EIP, CCIEBS, Modbus TCP communication protocols)

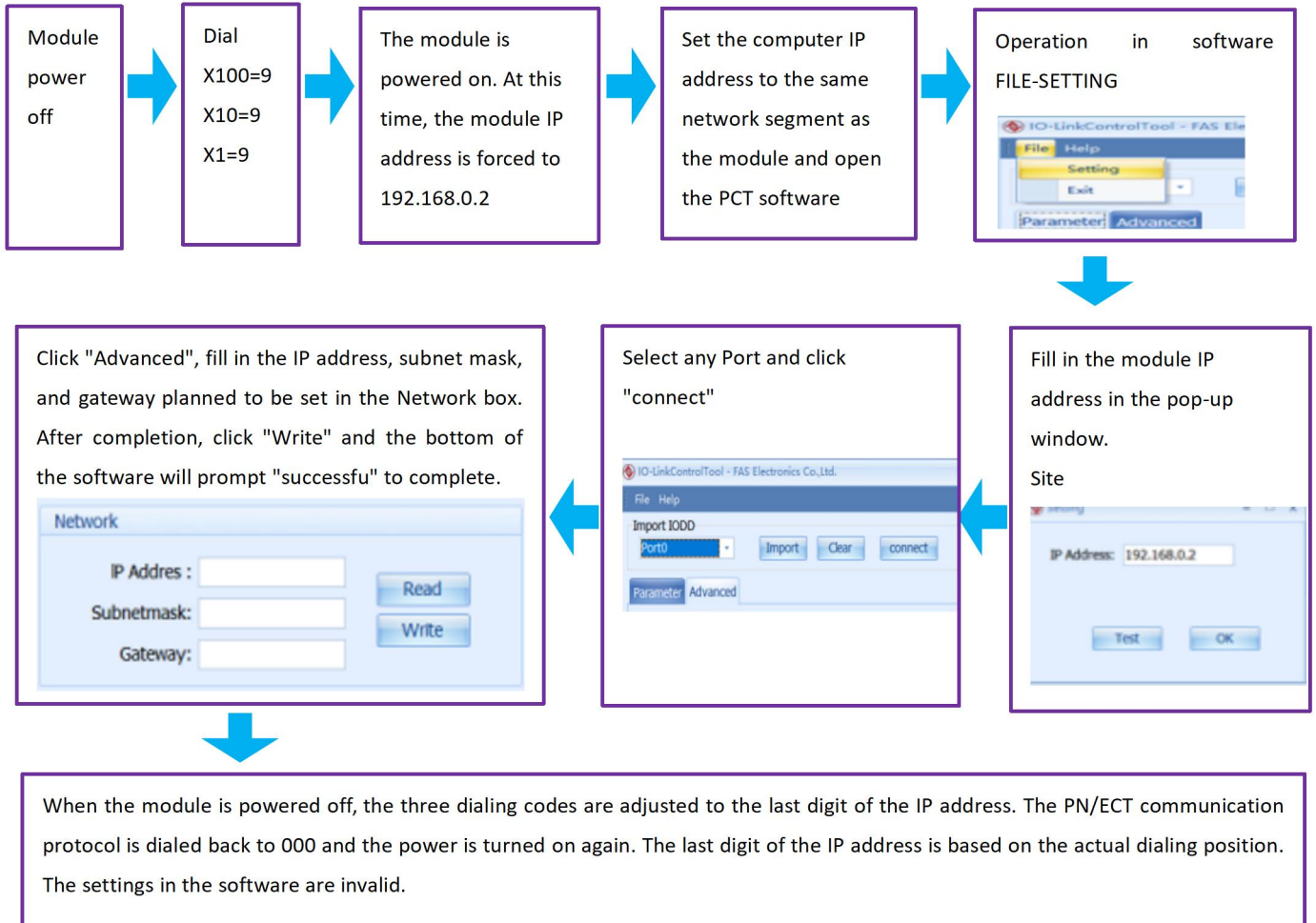

3.1.3 Setting the number of CCIEBS occupied stations

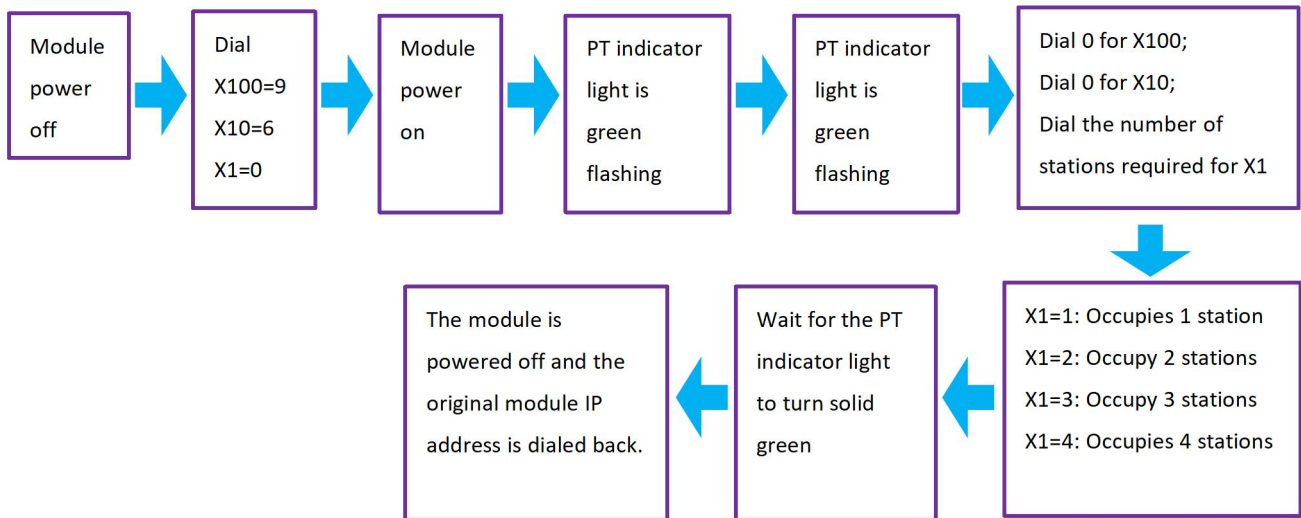

3.2 Data mapping

EIP communication protocol process output data									
Byte	Function description								
	Function description	Bit7	Bit6	Bit5	Bit4	Bit3	Bit2	Bit1	Bit0
0	Standard IO output 0=off 1=on	Port7 Pin4	Port6 Pin4	Port5 Pin4	Port4 Pin4	Port3 Pin4	Port2 Pin4	Port1 Pin4	Port0 Pin4
1		Port7 Pin2	Port6 Pin2	Port5 Pin2	Port4 Pin2	Port3 Pin2	Port2 Pin2	Port1 Pin2	Port0 Pin2
2 ~ 5	Reserve								
6 ~ 37	Port 0 process output data								
38 ~ 69	Port 1 process output data								
70 ~ 101	Port 2 process output data								
102 ~ 133	Port 3 process output data								
134 ~ 165	Port 4 process output data								
166 ~ 197	Port 5 process output data								
198 ~ 229	Port 6 process output data								
230 ~ 261	Port 7 process output data								

EIP communication protocol process input data

Byte	Function description								
	Function description	Bit7	Bit6	Bit5	Bit4	Bit3	Bit2	Bit1	Bit0
0	Standard IO input 0=no signal 1=There is signal	Port7 Pin4	Port6 Pin4	Port5 Pin4	Port4 Pin4	Port3 Pin4	Port2 Pin4	Port1 Pin4	Port0 Pin4
1	Standard IO input 0=no signal 1=There is signal	Port7 Pin2	Port6 Pin2	Port5 Pin2	Port4 Pin2	Port3 Pin2	Port2 Pin2	Port1 Pin2	Port0 Pin2
2	Pin4 short circuit 0=no short circuit 1=There is a short circuit	Port7 Pin4	Port6 Pin4	Port5 Pin4	Port4 Pin4	Port3 Pin4	Port2 Pin4	Port1 Pin4	Port0 Pin4
3	Pin2 short circuit 0=no short circuit 1=There is a short circuit	Port7 Pin2	Port6 Pin2	Port5 Pin2	Port4 Pin2	Port3 Pin2	Port2 Pin2	Port1 Pin2	Port0 Pin2
4	Pin1 short circuit 0=no signal 1=There is signal	Port7 Pin1	Port6 Pin1	Port5 Pin1	Port4 Pin1	Port3 Pin1	Port2 Pin1	Port1 Pin1	Port0 Pin1
5	IO-Link communication status 0=not connected 1=Connected	Port7	Port6	Port5	Port4	Port3	Port2	Port1	Port0
6	IOLink PD valid 0=disabled 1=enable	Port7	Port6	Port5	Port4	Port3	Port2	Port1	Port0
7	Module status	-	-	-	Us overvol tage	Ua overvol tage	Overh eat	Us Under voltag	Ua Under voltag

								e	e
8 ~ 9	Reserve								
10 ~ 41	Port 0 process input data								
42 ~ 73	Port 1 process input data								
74 ~ 105	Port 2 process input data								
106 ~ 137	Port 3 process input data								
138 ~ 169	Port 4 process input data								
170 ~ 201	Port 5 process input data								
202 ~ 233	Port 6 process input data								
234 ~ 265	Port 7 process input data								

EIP communication protocol configuration data									
Variable	Function description								
	Function description	Bit7	Bit6	Bit5	Bit4	Bit3	Bit2	Bit1	Bit0
Word	Pin4 Function 00=Normally open input 01=Normally closed input 10=output 11=IO-Link	Port3		Port2		Port1		Port0	
		Bit15	Bit14	Bit13	Bit12	Bit11	Bit10	Bit9	Bit8
		Port7		Port6		Port5		Port4	
Word	Pin2 Function 00=Normally open input 01=Normally closed input 10=output	Port3		Port2		Port1		Port0	
		Bit15	Bit14	Bit13	Bit12	Bit11	Bit10	Bit9	Bit8
		Port7		Port6		Port5		Port4	
Word	Pin4 SafeState 00 = remain at 0 01 = remain at 1 10 = keep the last value	Port3		Port2		Port1		Port0	
		Bit15	Bit14	Bit13	Bit12	Bit11	Bit10	Bit9	Bit8
		Port7		Port6		Port5		Port4	
Word	Pin2 SafeState 00 = remain at 0 01 = remain at 1 10 = keep the last value	Port3		Port2		Port1		Port0	
		Bit15	Bit14	Bit13	Bit12	Bit11	Bit10	Bit9	Bit8
		Port7		Port6		Port5		Port4	

Byte	Port0 configuration*	(1 byte) IO-Link CycleTime (1 byte) Validation Type (2 bytes) Vendor ID1~ID2 (3 bytes) Device ID1~ID3 (16 bytes) Serial Number1~16 (1 byte) Parameter Server
Byte	Port1 configuration*	(Same as above)
Byte	Port2 configuration*	(Same as above)
Byte	Port3 configuration*	(Same as above)
Byte	Port4 configuration*	(Same as above)
Byte	Port5 configuration*	(Same as above)
Byte	Port6 configuration*	(Same as above)
Byte	Port7 configuration*	(Same as above)

Note:

When using Omron and Delta PLC, the configuration data is set in the module properties, and AB PLC is set in the mapping data.

*Port configuration parameter description:

A. (1byte) IO-Link CycleTime cycle time setting:

This parameter can be used for IO-Link communication speed. Using multipliers and time base calculations, the IO-Link cycle time can be increased.

The time base is described in the table below. The multiplier is entered in decimal form from 0...63.

Bit								Description
7	6	5	4	3	2	1	0	
Time base		Multiplier						Bit 0 to 5: Multiplier These bits contain a 6-bit multiplier for the calculation of MasterCycleTime or MinCycleTime. Permissible values for the multiplier are 0 to 63. Bit 6 to 7: Time Base These bits specify the time base for the calculation of MasterCycleTime or WincycleTime.

Possible values for MasterCycleTime and MiniCycleTime

Time base encoding	Time base value	Calculation	Cycle time
00	0.1ms	Multiplier x time base	0.4 ms to 6.3 m
01	0.4ms	6.d ms + multppler x time base	6.4 ms to 31.6 ms
10	1.6ms	32,0 ms + multiplier x time base	32.0 ms to 132.8 ms
11	Resarved	Resarved	Resorved
NOTE: The value 0.4 results from the minimum possible transmission time according to A.3.7			

B. (1byte) Validation Type verification type setting:

(Value=0) No verification: Verification is disabled and every device will be accepted.

(Value = 1) Compatibility: Compare the manufacturer ID/device ID with the IO-Link device data.

(Value=2) Identity: Compares Manufacturer ID/Device ID/Serial Number with IO-Link device data. IO-Link communication only starts if there is a match.

C. (2bytes) Vendor ID1~ID2 manufacturer ID

D. (3bytes) Device ID1~ID3 device ID

E. (16bytes) Serial Number1~16 serial number

F. (1byte) Parameter Server parameter server (reserved)

ProfiNet communication protocol process monitoring data

Module	Function description								
	State illustrate	Bit7	Bit6	Bit5	Bit4	Bit3	Bit2	Bit1	Bit0
Actuator shutdown pin 2	Pin2 port short circuit 0=Normal 1=short circuit	Port7 Pin2	Port6 Pin42	Port5 Pin2	Port4 Pin2	Port3 Pin2	Port2 Pin2	Port1 Pin2	Port0 Pin2
Actuator shutdown pin 4	Pin4 port short circuit 0=Normal 1=short circuit	Port7 Pin4	Port6 Pin4	Port5 Pin4	Port4 Pin4	Port3 Pin4	Port2 Pin4	Port1 Pin4	Port0 Pin4
Sensor supply short circuit	Pin1 port short circuit 0=Normal 1=short circuit	Port7 Pin1	Port6 Pin1	Port5 Pin1	Port4 Pin1	Port3 Pin1	Port2 Pin1	Port1 Pin1	Port0 Pin1
Device Status	Module state	-	-	-	Us Overvoltage	Ua Overvoltage	Overheat	Us Under voltage	Ua Under voltage
IO-Link communication state	Communication status 0=Disconnect 1=Connect	Port7	Port6	Port5	Port4	Port3	Port2	Port1	Port0
IO-Link PD Valid	IO-Link PD valid 0=disabled 1=enable	Port7	Port6	Port5	Port4	Port3	Port2	Port1	Port0
Standard I/O	Standard IO auxiliary slot	(Match Input Pin2, Pin4, use Output Pin2, Pin4)							

CCIEBS communication protocol process output data

Byte	Function description								
	Function description	Bit7	Bit6	Bit5	Bit4	Bit3	Bit2	Bit1	Bit0
RY (Maximum 256Bit)	Standard IO output	Port7 Pin4	Port6 Pin4	Port5 Pin4	Port4 Pin4	Port3 Pin4	Port2 Pin4	Port1 Pin4	Port0 Pin4
	0=off 1=on	Port7 Pin2	Port6 Pin2	Port5 Pin2	Port4 Pin2	Port3 Pin2	Port2 Pin2	Port1 Pin2	Port0 Pin2
	(The rest of the points are reserved)								
RWW (Maximum 256Byte)	Port 0 process output data (32Byte)								
	Port 1 process output data (32Byte)								
	Port 2 process output data (32Byte)								
	Port 3 process output data (32Byte)								
	Port 4 process output data (32Byte)								
	Port 5 process output data (32Byte)								
	Port 6 process output data (32Byte)								
	Port 7 process output data (32Byte)								

CCIEBS communication protocol process input data

Byte	Function description								
	Function description	Bit7	Bit6	Bit5	Bit4	Bit3	Bit2	Bit1	Bit0
RX (Maximum 256Bit)	Standard IO input 0=No signal 1=There is signal	Port7 Pin4	Port6 Pin4	Port5 Pin4	Port4 Pin4	Port3 Pin4	Port2 Pin4	Port1 Pin4	Port0 Pin4
	Standard IO input 0=No signal 1=There is signal	Port7 Pin2	Port6 Pin2	Port5 Pin2	Port4 Pin2	Port3 Pin2	Port2 Pin2	Port1 Pin2	Port0 Pin2
	Pin4 short circuit 0=no short circuit 1=There is a short circuit	Port7 Pin4	Port6 Pin4	Port5 Pin4	Port4 Pin4	Port3 Pin4	Port2 Pin4	Port1 Pin4	Port0 Pin4
	Pin2 short circuit 0=no short circuit 1=There is a short circuit	Port7 Pin2	Port6 Pin2	Port5 Pin2	Port4 Pin2	Port3 Pin2	Port2 Pin2	Port1 Pin2	Port0 Pin2
	Pin1 short circuit 0=no short circuit 1=There is a short circuit	Port7 Pin1	Port6 Pin1	Port5 Pin1	Port4 Pin1	Port3 Pin1	Port2 Pin1	Port1 Pin1	Port0 Pin1
	IO-Link communication status 0=not connected 1=Connected	Port7	Port6	Port5	Port4	Port3	Port2	Port1	Port0
	IO-Link PD is valid 0=disabled 1=enable	Port7	Port6	Port5	Port4	Port3	Port2	Port1	Port0
	Module status	-	-	-	Us Overvoltage	Ua Overvoltage	Overheat	Us Under voltage	Ua Under voltage
(The rest of the points are reserved)									
RWR (Maximum 256Byte)	Port 0 process input data (32Byte)								
	Port 1 process input data (32Byte)								
	Port 2 process input data (32Byte)								
	Port 3 process input data (32Byte)								
	Port 4 process input data (32Byte)								

	Port 5 process input data (32Byte)
	Port 6 process input data (32Byte)
	Port 7 process input data (32Byte)

Note:

1. Please set the CCIEBS master port function in the FAS IOLink Tool software.
2. Points of 64 occupy 1 station, and the slave station connected to each port uses 4 words of points.
3. Points 128 occupy 2 stations, and the slave station connected to each port uses 8 words of points.
4. Points 192 occupy 3 stations, and the slave station connected to each port uses 12 words.
5. Points 256 occupy 4 stations, and the slave station connected to each port uses 16 words of points.
6. Refer to Chapter 5.1.3 for point setting. The CCIEBS master station occupies 4 stations by default.

Modbus TCP communication protocol process output data

Byte	Function description								
	Function description	Bit7	Bit6	Bit5	Bit4	Bit3	Bit2	Bit1	Bit0
Word40001	Standard IO output 0=off 1=on	Port7 Pin4	Port6 Pin4	Port5 Pin4	Port4 Pin4	Port3 Pin4	Port2 Pin4	Port1 Pin4	Port0 Pin4
		Bit15	Bit14	Bit13	Bit12	Bit11	Bit10	Bit9	Bit8
		Port7 Pin2	Port6 Pin2	Port5 Pin2	Port4 Pin2	Port3 Pin2	Port2 Pin2	Port1 Pin2	Port0 Pin2
Word40002 - Word40003	Reserve								
Word40004 - Word40019	Port 0 process output data								
Word40020 - Word40035	Port 1 process output data								
Word40036 - Word40051	Port 2 process output data								
Word40052 - Word40067	Port 3 process output data								
Word40068 - Word40083	Port 4 process output data								
Word40084 - Word40099	Port 5 process output data								
Word40100 - Word40115	Port 6 process output data								
Word40116 - Word40131	Port 7 process output data								

Modbus TCP communication protocol process input data

Byte	Function description								
	Function description	Bit7	Bit6	Bit5	Bit4	Bit3	Bit2	Bit1	Bit0
Word30001	Standard IO input	Port7 Pin4	Port6 Pin4	Port5 Pin4	Port4 Pin4	Port3 Pin4	Port2 Pin4	Port1 Pin4	Port0 Pin4
	0=no signal 1=There is signal	Bit15	Bit14	Bit13	Bit12	Bit11	Bit10	Bit9	Bit8
		Port7 Pin2	Port6 Pin2	Port5 Pin2	Port4 Pin2	Port3 Pin2	Port2 Pin2	Port1 Pin2	Port0 Pin2
Word30002	Pin4 short circuit	Bit7	Bit6	Bit5	Bit4	Bit3	Bit2	Bit1	Bit0
	0=no short circuit 1=There is a short circuit	Port7 Pin4	Port6 Pin4	Port5 Pin4	Port4 Pin4	Port3 Pin4	Port2 Pin4	Port1 Pin4	Port0 Pin4
	Pin2 short circuit	Bit15	Bit14	Bit13	Bit12	Bit11	Bit10	Bit9	Bit8
	0=no short circuit 1=There is a short circuit	Port7 Pin2	Port6 Pin2	Port5 Pin2	Port4 Pin2	Port3 Pin2	Port2 Pin2	Port1 Pin2	Port0 Pin2
Word30003	Pin1 short circuit	Bit7	Bit6	Bit5	Bit4	Bit3	Bit2	Bit1	Bit0
	0=no signal 1=There is signal	Port7 Pin1	Port6 Pin1	Port5 Pin1	Port4 Pin1	Port3 Pin1	Port2 Pin1	Port1 Pin1	Port0 Pin1
	IO-Link communication status	Bit15	Bit14	Bit13	Bit12	Bit11	Bit10	Bit9	Bit8
	0=not connected 1=Connected	Port7	Port6	Port5	Port4	Port3	Port2	Port1	Port0
Word30004	IO-Link PD valid	Bit7	Bit6	Bit5	Bit4	Bit3	Bit2	Bit1	Bit0
	0=disabled 1=enable	Port7	Port6	Port5	Port4	Port3	Port2	Port1	Port0
	Module status	Bit15	Bit14	Bit13	Bit12	Bit11	Bit10	Bit9	Bit8
		-	-	-	Us Overvo	Ua Overvo	Overheat	Us Under	Ua Under

				ltage	ltage		voltage	voltage
Word30005	Reserve							
Word30006 - Word30021	Port 0 process input data							
Word30022 - Word30037	Port 1 process input data							
Word30038 - Word30053	Port 2 process input data							
Word30054 - Word30069	Port 3 process input data							
Word30070 - Word30085	Port 4 process input data							
Word30086 - Word30101	Port 5 process input data							
Word30102 - Word30117	Port 6 process input data							
Word30118 - Word30133	Port 7 process input data							

3.3 PLC integration tutorial

(The module communication protocol should be set before configuring the module, see 5.1.1 for details)

3.3.1 Siemens S7-1200 Portal Integration (PN)

1、Install GSD file

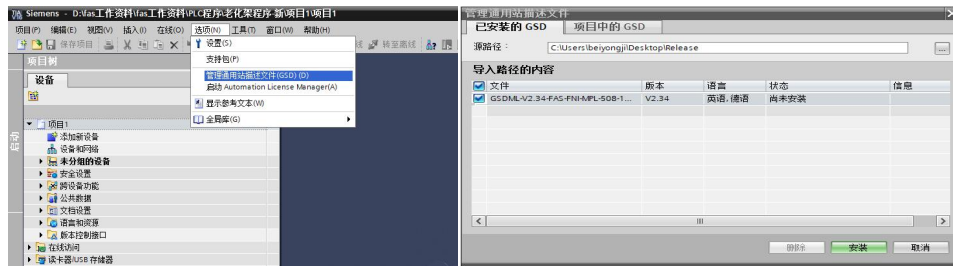

2. In PLC---Device Configuration---Network View---Hardware Catalog, select the module and drag it in, click "Unassigned", and select the PLC to be connected;

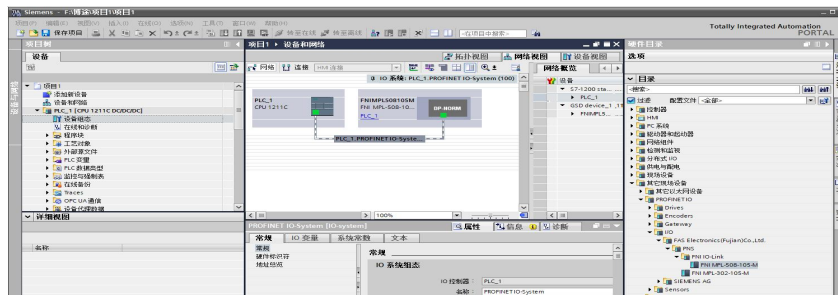

3. Double-click the module to enter the configuration.

(1) Slot function configuration: Select the required data in the hardware catalog--Module and drag it into the slot in the device overview window;

(2) Module port function configuration: Click the module icon, select "General", then click slot 1 to configure the port function

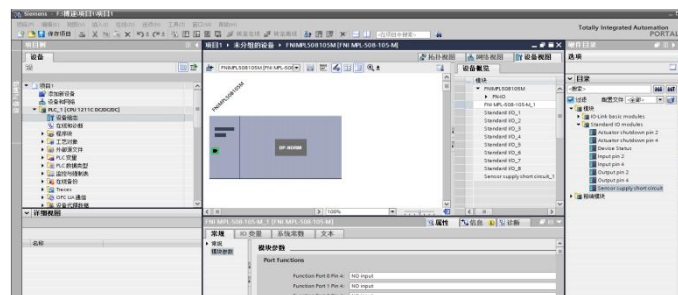

(3)Module function configuration: Click the module icon, select "General", then click slot 0 to configure the module function

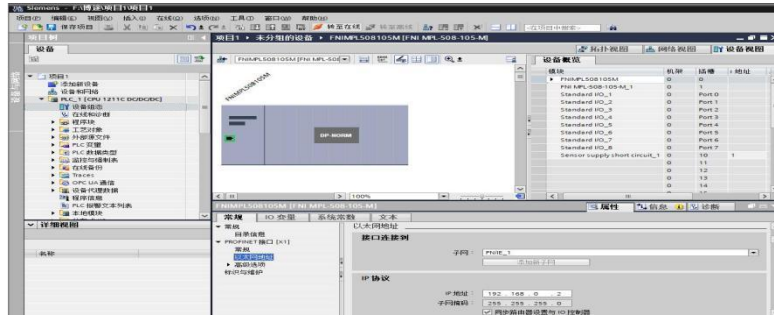

(4) After the configuration is completed, click Download in the configuration view.

3. Assign module PN name: PLC switches to online state, select "Ungrouped Device" --- Click on the module name ---- Select Online and Diagnosis --- Function --- Assign PROFINET device name --- -Select the module to be assigned in the list (should be selected based on the physical MAC)---Click "Assign Name" to complete the configuration!

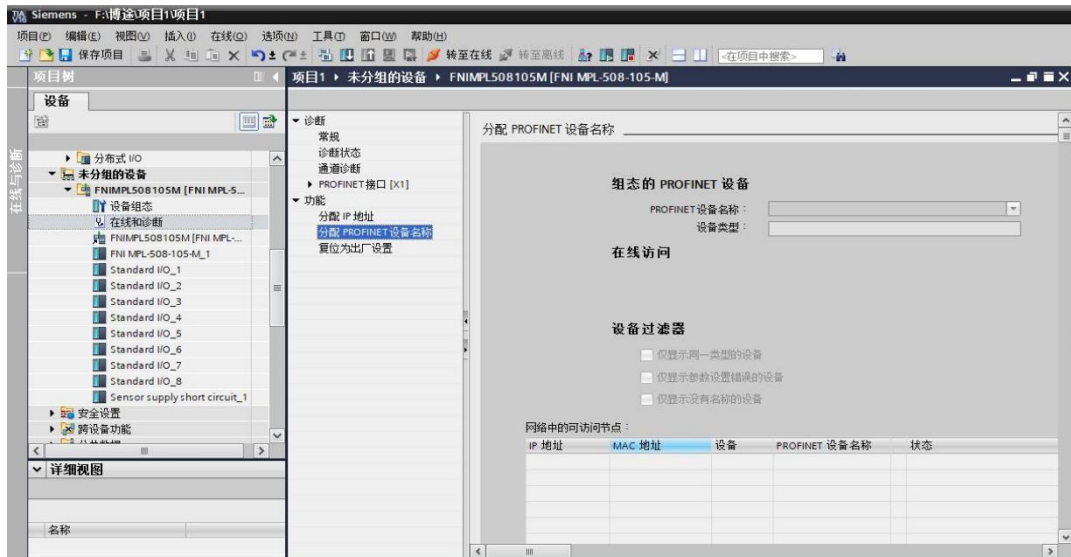

3.3.2 Omron NX1P2 Sysmac Studio Integrated (EIP)

1. Install the EDS file: Tools---ETHERNET/IP Connection Settings---Double-click the PLC in the window---right-click the blank space of the toolbox on the right and select "Show EDS Library", click "Install" in the pop-up window, and select EDS File installation

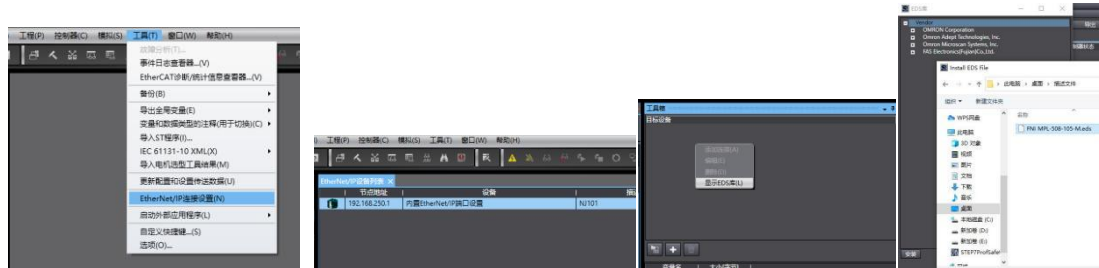

2. Create a module: Click "+" in the toolbox window, fill in the module IP address, model name, and version, click "Add" below, and the module creation is completed;

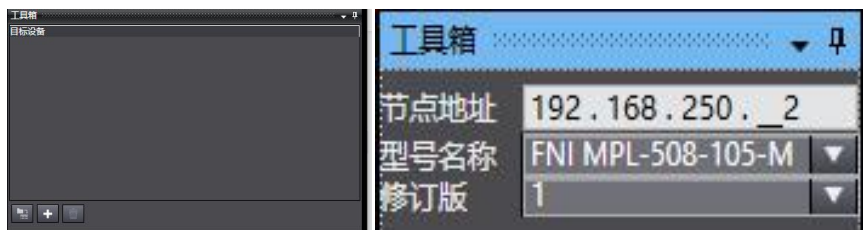

3. Configure the module: right-click the module--select "Edit"--configure the parameters according to actual needs and click OK after completing the corresponding values.



4. Create variable association:

- (1) Programming--Data--Global variables create two arrays, output 262 bytes and input 266 bytes. The corresponding input and output should be configured in the network exposure;

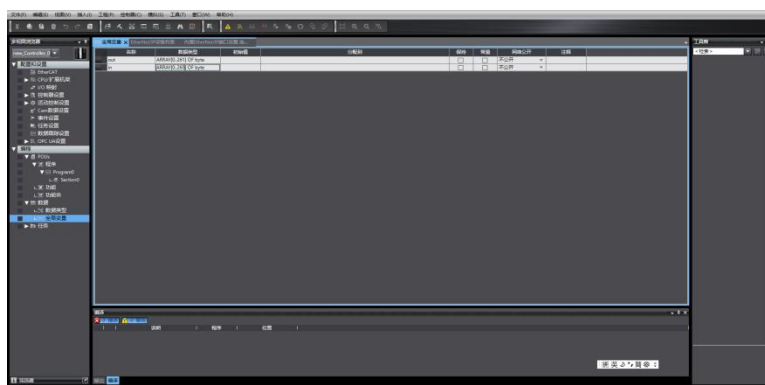

- (2) In the built-in ETHERNET/IP port setting window--select the first icon (label) on the left---click "Register All"

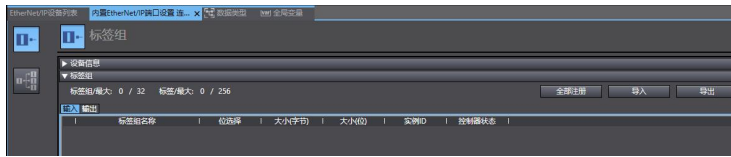

- (3) In the built-in ETHERNET/IP port setting window--select the second icon on the left (connection)---click "+", select the previously configured module for the target device, select EXCLUSIVE Owner for the IO type, and select the corresponding input For output, the target variable must be filled in 101,100; then select the corresponding starting variable and go online after completion. Select "Transfer to controller" and the configuration is complete!

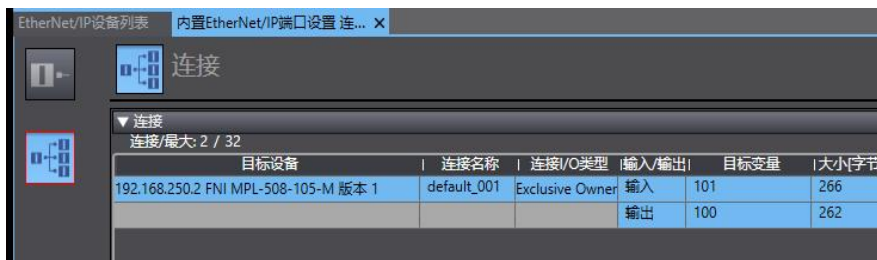

3.3.3 Mitsubishi FX5U Work2 Integrated (CIE)

1. Install the CCSP file: First open GX WORKS 3-Tools-Configuration File Management-Login-CSPP file (the project must be closed to import the file)

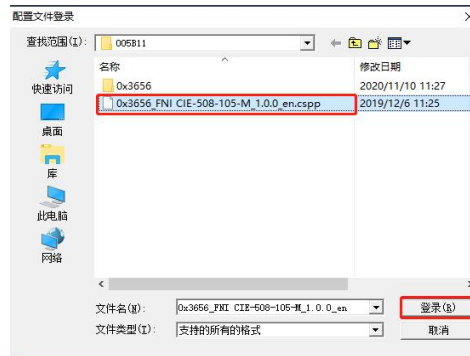

2. Click Project on the left - Parameters - FX5UCPU - Module parameters - Ethernet port, Basic settings - Self-node settings. Set own node IP

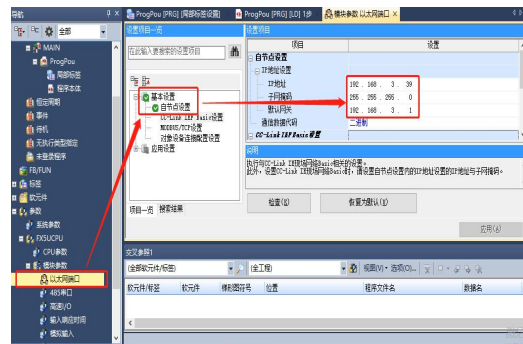

3. Click CC-Link IEF Basic settings - select whether to use CC-Link IEF Basic - click Use

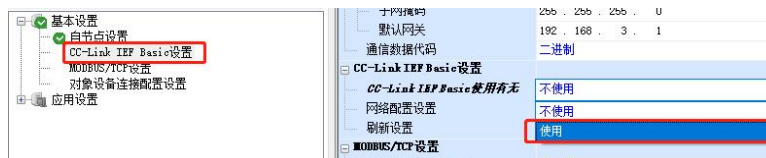

4. Click CC-Link IEF Basic settings-select network configuration settings-detailed settings;



5. Automatic detection of connected devices - occupies 4 stations, IP address is set using DIP switch - reflects the setting and closes



6.To refresh the target, select the specified device-software name M-assign the device address-application, and the configuration is completed!

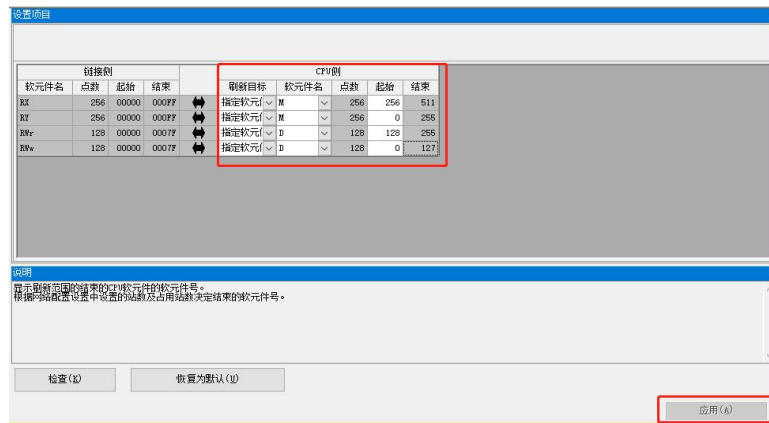

3.4 Modbus TCP communication configuration

3.4.1 Integrated in Inovance Autoshop

1. Create a new project, fill in the required project name, PLC model and programming method and confirm:

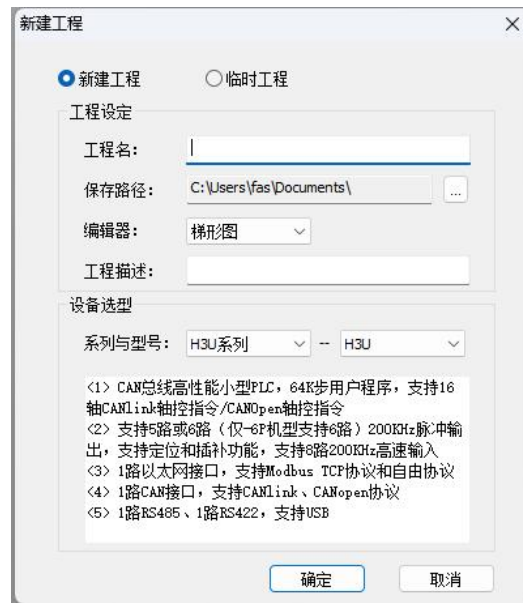

2. Modify the IP so that the PLC and module are in the same network segment:

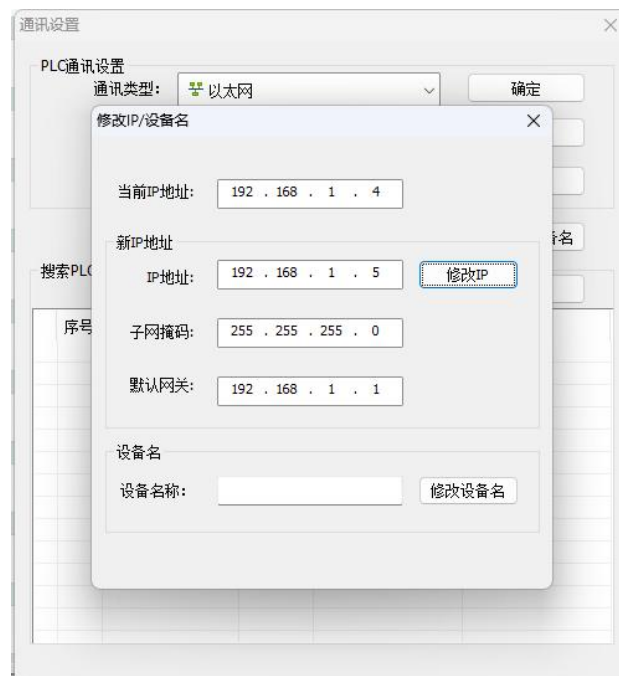

3. Add Modbus TCP configuration:

Select the Ethernet option in the left column and right click to add Ethernet configuration:



After entering the menu, fill in the IP address and port number of the module and click OK:



After clicking OK, a Modbus TCP connection device will be added:



Right-click the device and select Open to pop up the Modbus TCP configuration page. Click Add on the page and the configuration options shown below will appear. Change the function code, quantity, and mapping address to the values you need.

During this period, the address of the mapped input and output corresponds to the address of the read-write register in the module. After configuration, click OK:

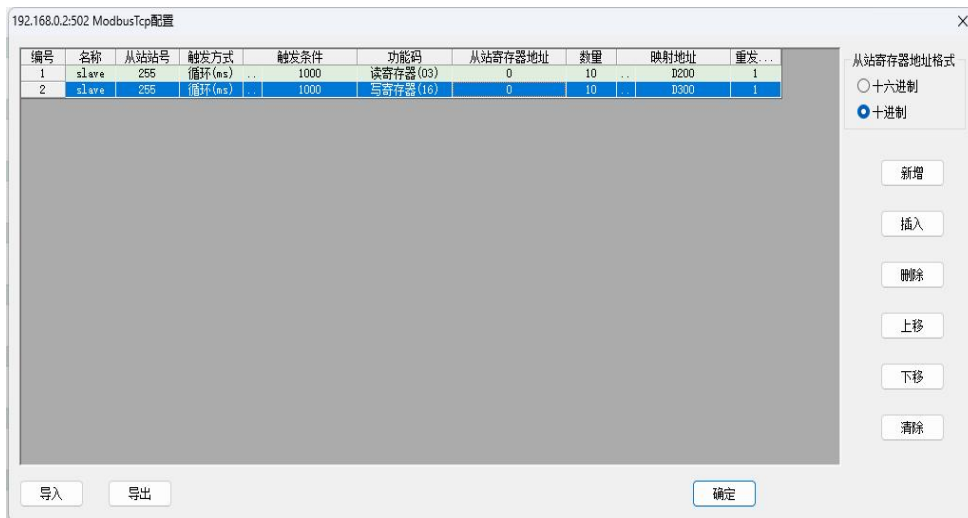

4. Download the program and test:

Click this button to download the program to the PLC. After completion, the PLC will be transferred to the online monitoring state.

During online monitoring, right-click in the information output window, select Batch Add and click:



After clicking to enter, select the software element type as D and fill in the starting address and ending address as the mapping addresses previously added on the Modbus TCP configuration page and click OK:

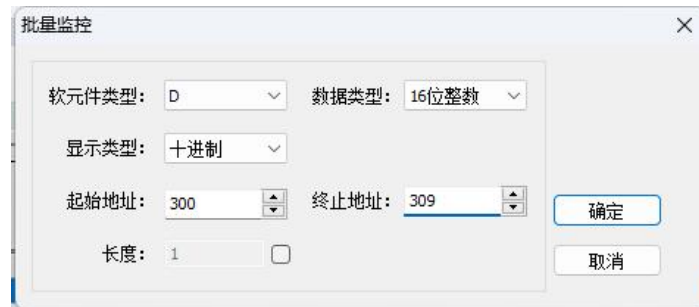

After adding the address, you can now test it. The following example uses the read register and write register to test.

At this time, D300 and D200 in the picture correspond to the 0th position of the module:

	元件名称	数据类型	显示格式	当前值
1	... D300	INT	十进制	0
2	... D200	INT	十进制	0

At this time, D300 is a write register and D200 is a read register. Write the value to the write register as 1. At this time, the read register value is also fed back to a coil of valve island 1 and turned on. At this time, the Modbus TCP configuration is completed:

	元件名称	数据类型	显示格式	当前值
1	... D300	INT	十进制	1
2	... D200	INT	十进制	1

3.4.2 Integrated in Siemens Portal

1. New construction

Create new project - enter project name - Create

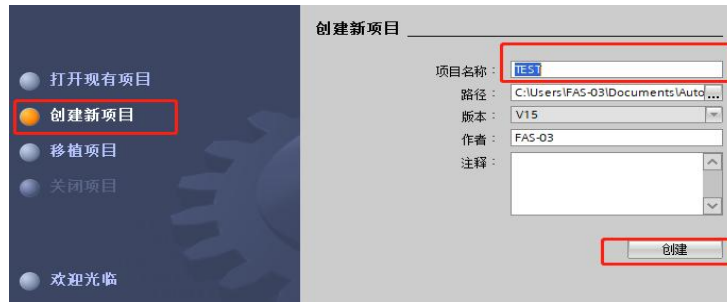

Devices and Networks-Add new device-Select the appropriate PLC and CPU model-Add



2. Create MUDBUS program

1. Call MB_CLIENT

Call the MB_CLIENT instruction block in the program segment in "Program Block > OB1".
When calling, the background DB will be automatically generated. Click OK:

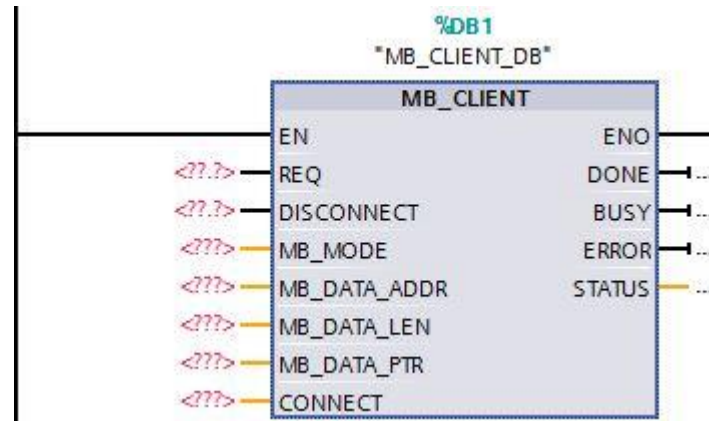

The first step is to create a new global data block DB2:



In the second step, double-click to open DB2, define the variable name as "aa", and the data type as "TCON_IP_v4" (TCON_IP_v4 can be copied to this dialog box), and then click the "Enter" button. The data type structure is created:

数据块_1		
名称	数据类型	启动值
Static		
aa	TCON_IP_v4	
InterfaceId	HW_ANY	16#0
ID	CONN_OUC	16#0
ConnectionType	Byte	16#0B
ActiveEstablished	Bool	false
RemoteAddress	IP_V4	
ADDR	Array[1..4] of Byte	
RemotePort	UInt	0
LocalPort	UInt	0

Definition of each parameter:

Parameter	Illustrate
InterfaceId	The network port hardware identifier is 64 for the main body network port, which is 16#40.
ID	Connection ID, value range 1~4095
Connection Type	Connection Type. The default TCP connection is: 16#0B
ActiveEstablished	establish connection. Active is 1 (client), passive is 0 (server).
ADDR	Server side IP address
RemotePort	Remote port number
LocalPort	local port number

The IP address of the remote server in this article is 192.168.0.4, and the remote port number is set to 502. So the values of the data structure on the client side are as shown in the figure:

数据块_1		
名称	数据类型	启动值
Static		
aa	TCON_IP_v4	
InterfaceId	HW_ANY	16#40
ID	CONN_OUC	16#1
ConnectionType	Byte	16#0B
ActiveEstablished	Bool	1
RemoteAddress	IP_V4	
ADDR	Array[1..4] of Byte	
ADDR[1]	Byte	16#c0
ADDR[2]	Byte	16#A8
ADDR[3]	Byte	16#0
ADDR[4]	Byte	16#04
RemotePort	UInt	502
LocalPort	UInt	0

- The CONNECT pin needs to be filled in with symbolic addressing.
- TCON_IP_v4 is a system data type and is not created in the PLC data type.
- LocalPort generally uses the default value 0, which means that a random port is used locally.

3. Create MB_DATA_PTR data buffer

The first step is to create a global data block DB3, which is located in the CPU program block together with the DB2 created in the previous step, as shown in the figure:

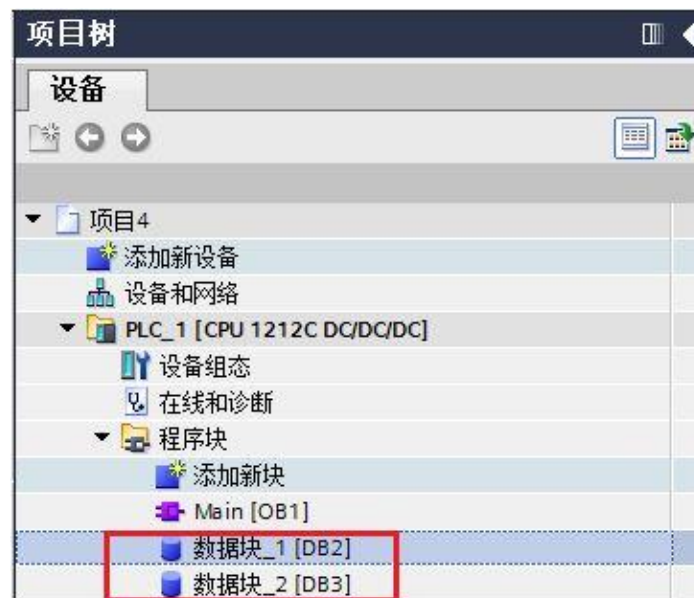

The second step is to establish a Word array data type to store data during communication, as shown in the figure.

数据块_2			
	名称	数据类型	启动值
1	Static		
2	ff	Array[0..10] of Word	
3	ff[0]	Word	16#0
4	ff[1]	Word	16#0
5	ff[2]	Word	16#0
6	ff[3]	Word	16#0
7	ff[4]	Word	16#0
8	ff[5]	Word	16#0
9	ff[6]	Word	16#0
10	ff[7]	Word	16#0
11	ff[8]	Word	16#0
12	ff[9]	Word	16#0
13	ff[10]	Word	16#0

- The data buffer specified by MB_DATA_PTR can be a DB block or M storage area address. DB blocks can be optimized data blocks or standard data block structures.
- If it is an optimized data block structure, it must be an array of basic data types, such as Int, Real, and Bool arrays. The pin needs to be filled in with symbolic addressing during programming;
- If it is a standard data block structure (you can right-click the DB block and uncheck "Optimized block access" in "Properties", as shown in Figure 9), you can fill in the pin in the form of a pointer.
- The data buffer specified by MB_DATA_PTR must be large enough, reaching at least MB_DATA_LEN bits (when accessing input bits, output bits) or words (when accessing holding registers, input words).

This article uses the standard data block (default) as an example for programming.



4. Complete instruction block programming on the client side

Call the MB_CLIENT instruction block and use function code 03 to read the values of 2 holding registers from the server. Refer to Table 4, so MB_MODE = 0, MB_DATA_ADDR = 40001, MB_DATA_LEN = 2, as shown in the figure:

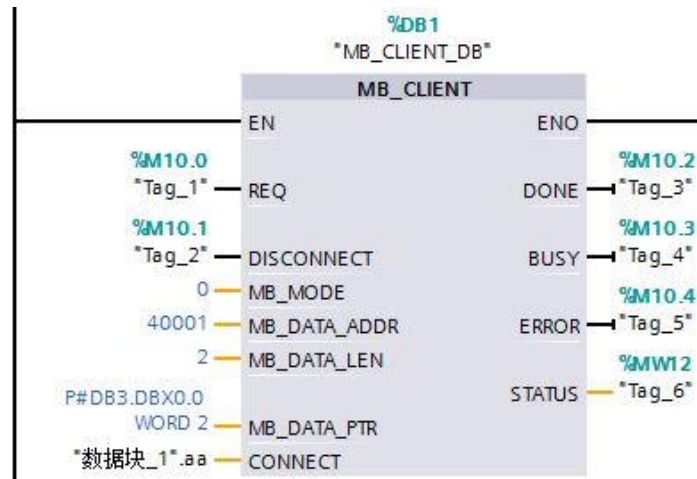

5. Download the entire project to the S7-1200

When the server side is ready, trigger a rising edge of the REQ pin of the instruction block and put the read data into the DB block variable specified by the MB_DATA_PTR pin.

4. Appendix

4.1. Materials included

- FNI MPL contains the following parts
- I/O-Block
- 4 blind plugs M12
- Ground bus
- Thread M4x6
- 20 tags

4.2. Order code

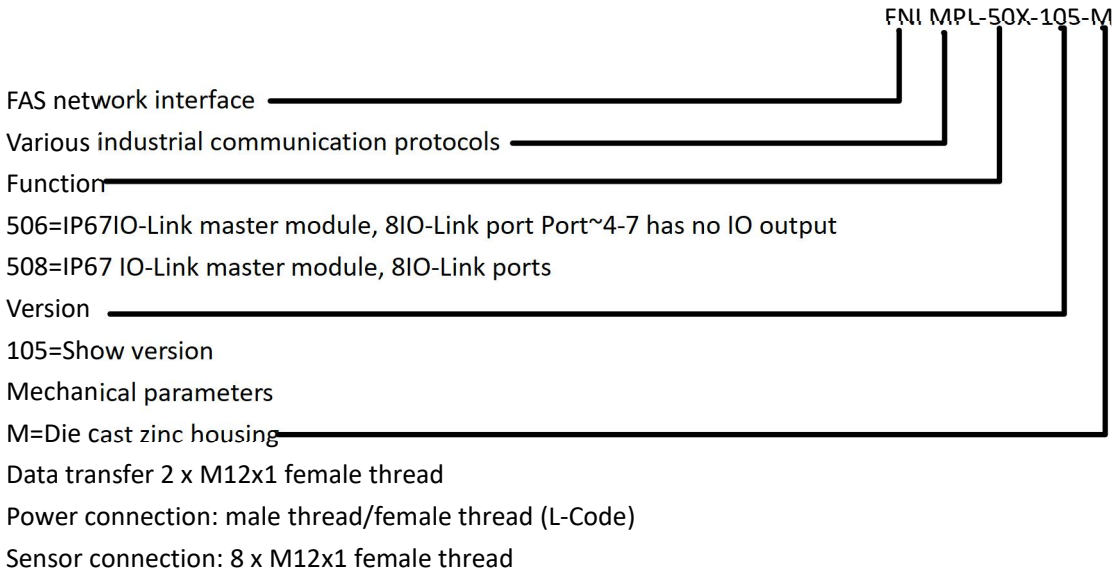

4.3 Ordering information

Product ordering code	Ordering code
FNI MPL-508-105-M	007B11

High quality products · Sincere service



[Technical support]



[Official website]



Telephone : 0591-22991876

Technical support : +86 13306936805

Official website: www.faselec.com

Business support : +86 19905006938

Address: Room 009, A1, Building 1, National University Science and Technology
Park Science and Technology Innovation Center, No. 6 Qiuyang East Road,
Shangjie Town, Minhou County, Fujian Province.