



PRODUCT

USE INSTRUCTIONS



[Technical support]

Ordering code: 00B514

Part number: FNI IOL-106-104-M08

IOL-106-104-M08

16 DO NPN

IP67 module user manual

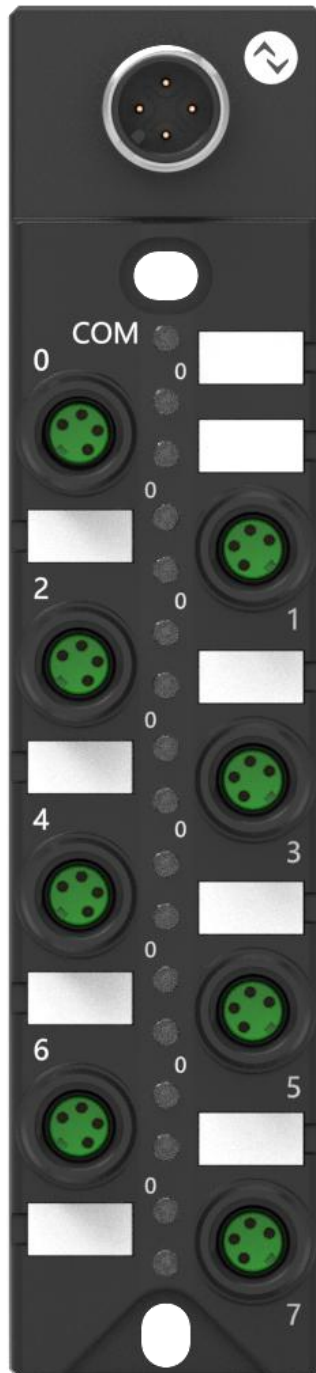

Contents

Security	4
■ Expected use	4
■ Installation and start-up	4
■ Corrosion resistance	4
■ Dangerous voltage	4
1 Getting started guide	6
1.1 Module overview	6
1.2 Mechanical connection	7
1.3 Electrical connections	7
2 Technical data	8
2.1. Size	8
2.2 Mechanical data	8
2.3 Operating conditions	9
2.4 Electrical data	9
2.5 IO-Link data	9
2.6 Process data/output data	9
2.7 Process data/input data	9
2.8 Parameter data/request data	10
2.9 Error	10
2.10 Event	11

Security

■ Expected use

This manual describes as decentralized input and output modules for connecting to an industrial network.

■ Installation and start-up

Precautions!

Installation and start-up may only be performed by trained personnel. A qualified individual is one who is familiar with the installation and operation of the product and has the necessary qualifications to perform such operations. Any damage caused by unauthorized operation or illegal and improper use is not covered by the manufacturer's warranty. The equipment operator is responsible for ensuring that appropriate safety and accident prevention regulations are observed.

■ Corrosion resistance

Precautions!

FNI modules generally have good chemical and oil resistance. When used in corrosive media (e.g. high concentrations of chemicals, oils, lubricants, coolants and other material media (i.e. very low water content), these media must be checked before the corresponding application material compatibility. If a module fails or is damaged due to this corrosive medium, a defect claim cannot be made.

■ Dangerous voltage

Precautions!

Disconnect all power before using the device!

■ General security

Debugging and inspection	Trouble	Owner/operator obligations	Expected use
<p>Before debugging, read the user manual carefully.</p>	<p>If the defect or equipment failure cannot be corrected, the operation of the equipment must be stopped to avoid damage that may be caused by unauthorized use.</p>	<p>This equipment is an EMC Class A compliant product. This device produces RF noise.</p>	<p>The warranty and limited liability statement provided by the manufacturer does not cover damage caused by:</p> <ul style="list-style-type: none"> ·Unauthorized tampering ·Improper use operation <p>·The instructions provided in the user manual explain the use, installation and handling of discrepancies</p>
<p>This system cannot be used in an environment where the safety of personnel depends on the functionality of the equipment.</p>	<p>Only after the housing is fully installed can the intended use be assured.</p>	<p>The owner/operator must take appropriate precautions to use this equipment.</p> <p>This device can only use the power supply that matches this device, and can only connect cables approved for application.</p>	

1 Getting started guide

1.1 Module overview

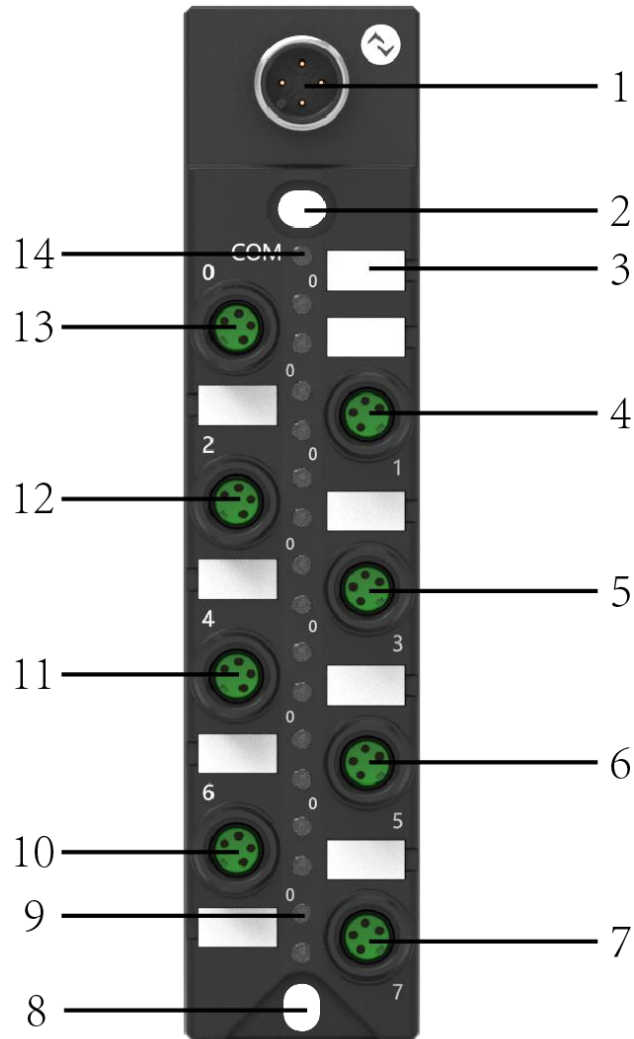

Figure 1

- | | |
|--------------------------|--|
| 1 IO-Link interface | 8 Fixing holes |
| 2 Fixing holes | 9 Port LED: Standard input port 7, Pin 4 |
| 3 Label | 10 Standard Output Port 6 |
| 4 Standard output port 1 | 11 Standard output port 4 |
| 5 Standard output port 3 | 12 Standard output port 2 |
| 6 Standard output port 5 | 13 Standard output port 0 |
| 7 Standard output port 7 | 14 Status LED: Communication/Module |

Indicator light	State	Describe
Port LED	Yellow LED indicator	Input status is normal
State LED	Green, pulse	Communication is normal
	Red indicator	Communication abnormality

1.2 Mechanical connection

The modules are connected using 2 M4 bolts and 2 washers.

Isolation pads are available as accessories.

1.3 Electrical connections

1.3.1 IO-Link interface(A-code)

M12,A-Coded, Male

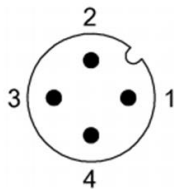

Pin	Function
1	Power US, +24 V
2	Actuator power supply UA, +24V
3	GND
4	C/Q, IO-Link data transmission channel

Figure 2

1.3.2 Standard input interface

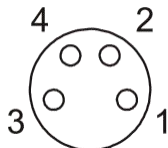

Pin	Function
1	+24 V
2	Output signal B,NPN
3	GND
4	Output signal A,NPN

Figure 3

Note:

Unused I/O port sockets must be covered with dust caps to meet IP67 protection rating.

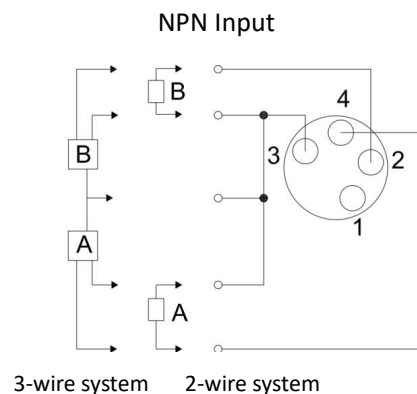

2 **Technical data**

2.1. Size

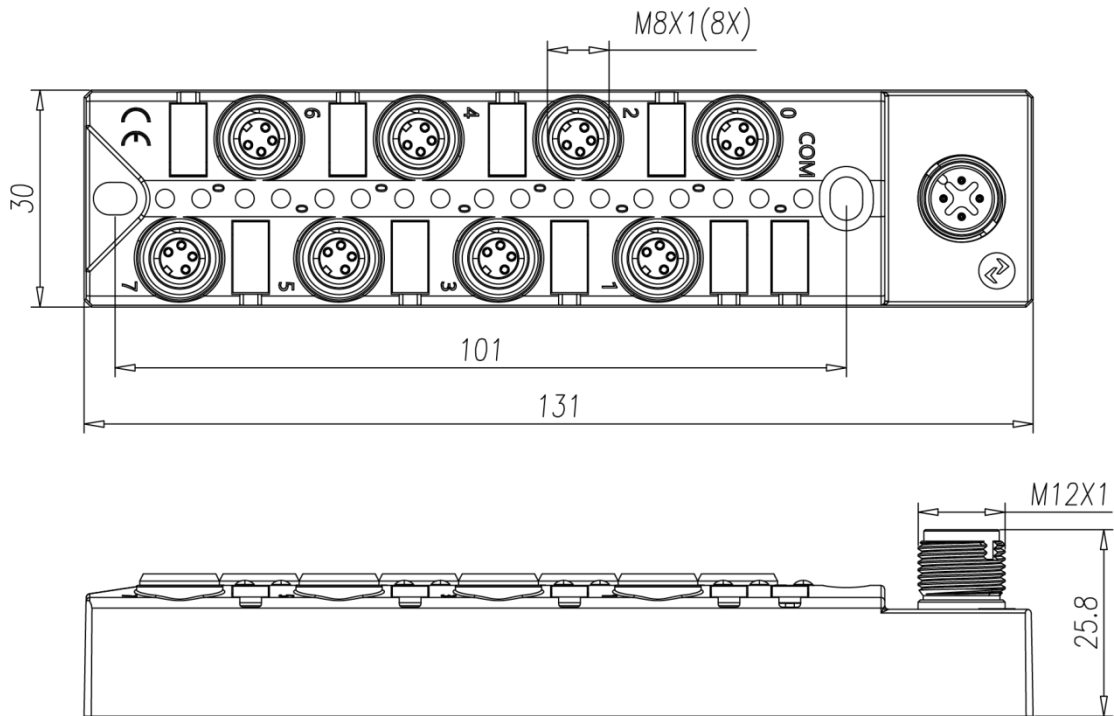

2.2 Mechanical data

Shell material	Plastic
Housing rating according to IEC 60529	IP67 (only in plug-in or plug type)
IO-Link interface	A-Coded
Input port	M8(8*Female)
Size(W*H*D)	30mm*131mm*25.8mm
Installation type	2-Through hole mounting
Weight	About 107 g

2.3 Operating conditions

Operating temperature	-5°C ~ 70°C
Storage temperature	-25°C ~ 70°C

2.4 Electrical data

Voltage	18~30V DC, conform to EN61131-2
Voltage fluctuation	<1%
Total current	<800mA

2.5 IO-Link data

As shown in Table 1-1.

Surface 1-1

Data transmission baud rate	COM2 (38.4kbit/s)
Frame type	2.V
Minimum cycle time	2.2ms
Process data cycle time	2.2ms, corresponds to the minimum cycle time
Process data length	2

2.6 Process data/output data

As shown in Figure 4.

Byte	1								0							
Bit	7	6	5	4	3	2	1	0	7	6	5	4	3	2	1	0
Describe	PORT7 PIN2.1	PORT6 PIN4.1	PORT7 PIN2.1	PORT6 PIN4.1	PORT7 PIN2.1	PORT6 PIN4.1	PORT7 PIN2.1	PORT6 PIN4.1	PORT7 PIN2.0	PORT6 PIN4.0	PORT7 PIN2.0	PORT6 PIN4.0	PORT7 PIN2.0	PORT6 PIN4.0	PORT7 PIN2.0	PORT6 PIN4.0

Figure 4

2.7 Process data/input data

No output data is defined.

2.8 Parameter data/request data

As shown in Figure 5.

	DPP	SPDU		Object name	length	Scope	Defaults
	Index	Index	Subindex				
Identification data				Supplier ID	2		0x0454
				Device ID	3		0x0994D2
		0x10	0	Supplier name	18	Read only	FAS(Fujian)Co.,LTD
		0x11	0	Supplier text	16		www.fas-elec.com
		0x12	0	Product name	20		FNI IOL-106-104-M08
		0x13	0	Product ID	6		00B514
		0x14	0	Product text	12		IO-Link M8 NPN 16DO
		0x16	0	Hard ware version	3		20200723
	0x17	0	Firmware version	3	2.01		
Parameter data		0x40	0	Bit reversal	2	0000-FFFF	0x0000

Figure 5

Note:

The 0x40 setting bit is reversed: 0-bit is not reversed, 1-bit is reversed. For example, the external input is 0x0000. When 0x40 is 0x0000, the value is 0x0000 (not reversed). When 0x40 is 0xFFFF, the value is 0xFFFF (reverse).

2.9 Error

As shown in Figure 6.

Error code	Additional code
Device application error 0x80	Index not available 0x11
	Subindex not available 0x12
	Value out of range 0x30

Figure 6

2.10 Event

As shown in Figure 7.

Class/qualifier			Code (high + low)			
Model	Type	Example				
Appear	Mistake	AL	Device hardware	Powered by	Power supply low voltage	U2=Powered by+24V
0xC0	0x30	0x03	0x5000	0x0100	0x0010	0x0002
0xF3			0x5112			
Disappea r	Mistake	AL	Device hardware	Powered by	Power supply low voltage	U2=Powered by+24V
0x80	0x30	0x03	0x5000	0x0100	0x0010	0x0002
0xB3			0x5112			
Appear	Mistake	AL	Device hardware	Powered by	Power supply for peripherals	
0xC0	0x30	0x03	0x5000	0x0100	0x0060	
0xF3			0x5160			
Disappea r	Mistake	AL	Device hardware	Powered by	Power supply for peripherals	
0x80	0x30	0x03	0x5000	0x0100	0x0060	
0xB3			0x5160			

Figure 7

High quality products · Sincere service



[Technical support]



[Official website]



Telephone : 0591-22991876

Technical support : +86 13306936805

Official website: www.faselec.com

Business support : +86 19905006938

Address: Room 009, A1, Building 1, National University Science and Technology
Park Science and Technology Innovation Center, No. 6 Qiuyang East Road,
Shangjie Town, Minhou County, Fujian Province.