



PRODUCT

USE INSTRUCTIONS



[Technical support]

Ordering code: 009E12

Part number: FNI ECT-306-002-K54

IP20 Module User Manual

16DI/DO NPN adaptive

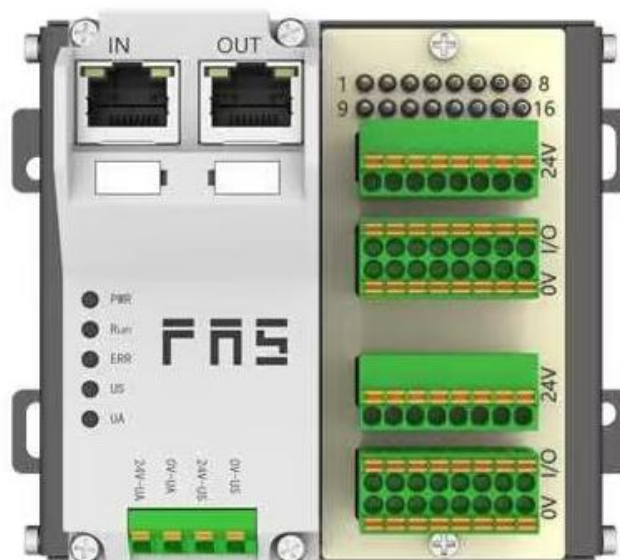

Catalog

Security	4
■ Expected use	4
■ Installation and start-up	4
■ Corrosion resistance	4
■ Dangerous voltage	4
1 Getting started guide	6
1.1 Module overview	6
1.2 Mechanical connection	7
1.3 Electrical connection	7
1.3.1 Power interface (terminal type)	7
1.3.2 Network interface (RJ45)	7
1.3.3 Signal port (screw free spring type terminal block)	8
2 Technical data	9
2.1. Size	9
2.2 Mechanical data	9
2.3 Operating conditions	9
2.4 Electrical data	10
2.5 Network port	10
2.6 Function indicator	10
3 Integration	12
3.1 Data mapping	12
3.2 PLC Integration Tutorial	13
3.2.1 Omron NX1P2 Integrated in Sysmac Studio (ECT)	13
4 Appendix	16
4.1 Ordering Information	16

■ Expected use

This manual describes as decentralized input and output modules for connecting to an industrial network.

■ Installation and start-up

Precautions!

Installation and start-up may only be performed by trained personnel. A qualified individual is one who is familiar with the installation and operation of the product and has the necessary qualifications to perform such operations. Any damage caused by unauthorized operation or illegal and improper use is not covered by the manufacturer's warranty. The equipment operator is responsible for ensuring that appropriate safety and accident prevention regulations are observed.

■ Corrosion resistance

Precautions!

FNI modules generally have good chemical and oil resistance. When used in corrosive media (e.g. high concentrations of chemicals, oils, lubricants, coolants and other material media (i.e. very low water content), these media must be checked before the corresponding application material compatibility. If a module fails or is damaged due to this corrosive medium, a defect claim cannot be made.

■ Dangerous voltage

Precautions!

Disconnect all power before using the device!

■ General security

Debugging and inspection	Trouble	Owner/operator obligations	Expected use
<p>Before debugging, read the user manual carefully.</p>	<p>If the defect or equipment failure cannot be corrected, the operation of the equipment must be stopped to avoid damage that may be caused by unauthorized use.</p>	<p>This equipment is an EMC Class A compliant product. This device produces RF noise.</p>	<p>The warranty and limited liability statement provided by the manufacturer does not cover damage caused by:</p> <ul style="list-style-type: none"> ·Unauthorized tampering ·Improper use operation <p>·The instructions provided in the user manual explain the use, installation and handling of discrepancies</p>
<p>This system cannot be used in an environment where the safety of personnel depends on the functionality of the equipment.</p>	<p>Only after the housing is fully installed can the intended use be assured.</p>	<p>The owner/operator must take appropriate precautions to use this equipment.</p> <p>This device can only use the power supply that matches this device, and can only connect cables approved for application.</p>	

1 Getting started guide

1.1 Module overview

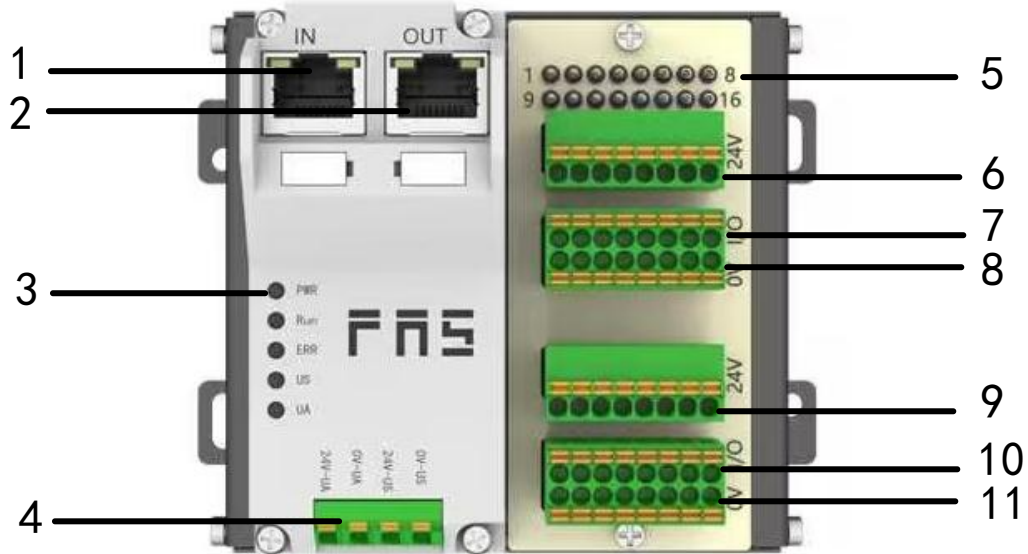

- | | | | |
|---|-----------------------------------|----|-----------------------------------|
| 1 | Network Input | 7 | 1-8 Signal interface |
| 2 | Network output | 8 | Sensor actuator power supply 0V |
| 3 | Module Status Indicator | 9 | Sensor actuator power supply +24V |
| 4 | Power supply interface | 10 | 9-16 Signal interface |
| 5 | Module Status Indicator | 11 | Sensor actuator power supply 0V |
| 6 | Sensor actuator power supply +24V | | |

1.2 Mechanical connection

The module is mounted using 4 M4 bolts or DIN35 rail clamps.

1.3 Electronic connection

1.3.1 Power connector (terminal type)

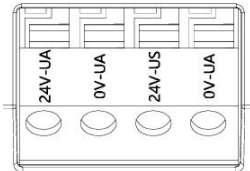

Pin	Function	Describe
1	Ua+	+24V
2	Ua-	0V
3	Us+	+24V
4	Us-	0V

Power connector

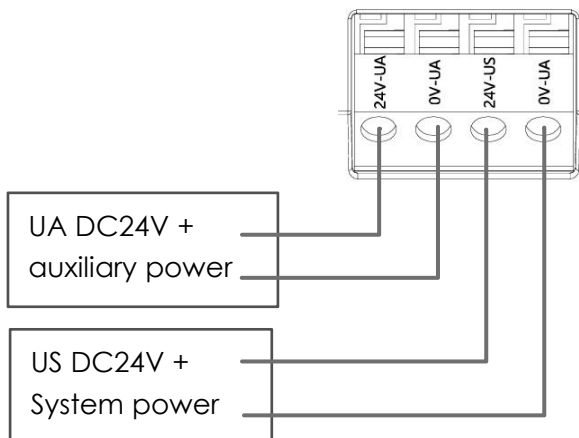

Note:

- 1、 Separate US power supplies and UA power supplies are recommended.
- 2、 Total UA power supply current <math>< 4A</math>, total Us power supply current <math>< 1A</math>;

1.3.2 Network interface(RJ45)

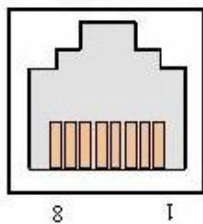

Pin	Function	
1	TD+	Send data+
2	TD-	Receive data-
3	RD+	Send data+
4	Empty	-
5	Empty	-
6	RD-	Receive data-
7	Empty	-
8	Empty	-

1.3.3 Signal port (screwless spring-type terminal block)

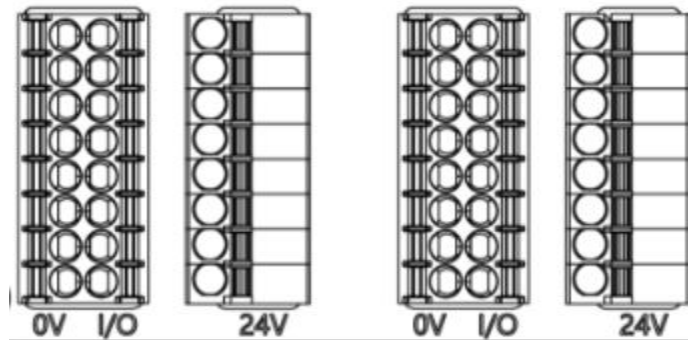

Note:

- 1、1, input and output signal type support: three-wire NPN, two-wire NPN, dry contact;
- 2、Pin +24V Single output current max. 500mA. total module current <4A;
- 3、Total current <1A per 8 channels (1~8 , 9~16)

General I/O

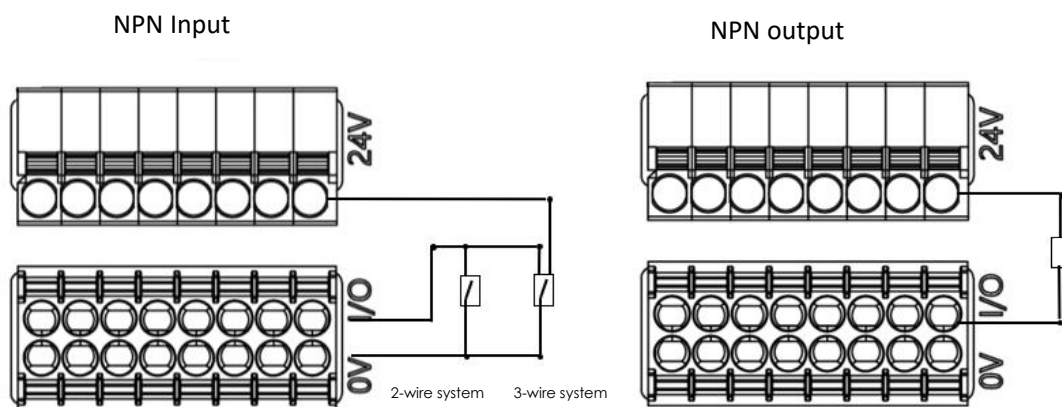

2 Technical data

2.1. Size

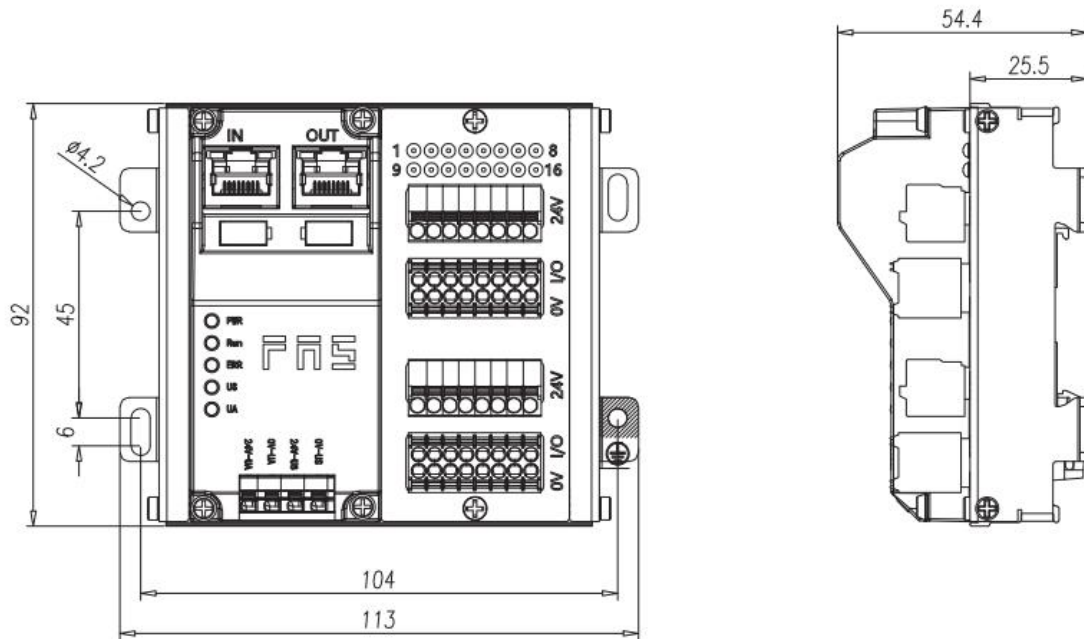

2.2 Mechanical data

Shell material	Aluminum shell
Shell grade conform to IEC 60529	IP20
Power interface	Terminal type
Input port/output port	Pluggable Screwless Quick Connect Terminals
Size(W*H*D)	113mm*92mm*54.4mm
Installation type	Screw fixing or DIN35 rail mounting
Weight	About 270g

2.3 Operating condition

Operating temperature	-5°C ~ 80°C
Storage temperature	-25°C ~ 85°C

2.4 Electrical data

Supply Voltage	18~30V DC, conform to EN61131-2
Voltage fluctuation	< 1%
Input current at supply voltage 24V	<130mA

2.5 Network port

Port connection	RJ45
Cable Types for Conform to IEEE 802.3	Shielded twisted pair, min STP CAT 5/STP CAT 5e
Data transmission rate	100 M bit/s
Maximum cable length	100m
Flow control	Full working conditions (IEEE 802.3-PAUSE)

2.6 Function indicator

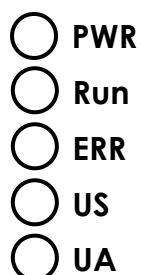

Meaning of the indicator status during EtherCAT communication protocol		
LED	Demonstrate	Function
PWR	Blue	EtherCAT protocol
RUN	Green light off	The device is in the initial state
	Green light flashing 2.5HZ	Pre operation: The device is in a pre operation state
	Green light flashing 1HZ	Safe operation: The device is in a safe operating state
	Green always on	Running: The device is in a running state
ERR	closure	No error: EtherCAT communication on device is working
	Red flashing 2.5HZ	Invalid Configuration
	Red flashing 1HZ	local error
	Red light, double blinking	Application monitoring timeout
US	Green	Input voltage is normal
	Red flashing	Low input voltage (< 18 V)
UA	Green	Output voltage is normal
	Red flashing	Low output voltage (< 18 V)
	Red Always On	There is no output voltage (< 11 V)

RJ45 port status

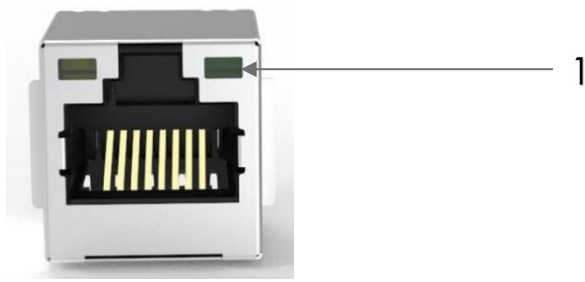

LED	State	Function
1	Green always on	Device connected to Ethernet
1	Closure	The device is not connected to the Ethernet

I/O port state

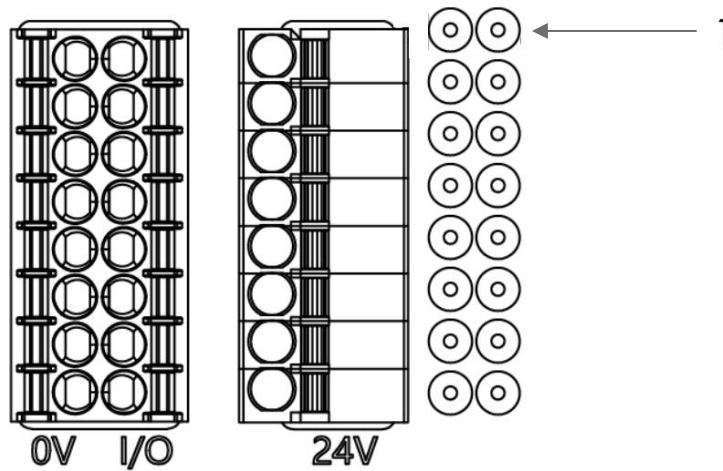

LED	State	Function
1	Closure	State of I/O pin input or output is 0
1	Yellow	State of I/O pin input or output is 1

3 integrated

3.1 Data mapping

ECT process input data									
Bytes	Functional Description								
	Status Description	Bit7	Bit6	Bit5	Bit4	Bit3	Bit2	Bit1	Bit0
0	1~8 signal input 0=Off, 1=On	Route 8	Route 7	Route 6	Route 5	Route 4	Route 3	Route 2	Route 1
1	9~16 signal input 0=Off, 1=On	Route 16	Route 15	Route 14	Route 13	Route 12	Route 11	Route 10	Route 9
Data description (binary): 0 = without signal 1 = with signal									

ECT process input data									
Bytes	Functional Description								
	Status Description	Bit7	Bit6	Bit5	Bit4	Bit3	Bit2	Bit1	Bit0
0	1~8 signal output 0=Off, 1=On	Route 8	Route 7	Route 6	Route 5	Route 4	Route 3	Route 2	Route 1
1	9~16 signal input 0=Off, 1=On	Route 16	Route 15	Route 14	Route 13	Route 12	Route 11	Route 10	Route 9
Data description (binary): 0=off 1=on									

3.2 PLC Integration Tutorial

3.2.1 Integration in Omron NX1P2 Sysmac Studio (ECT)

1、 Create a new project, identify the device type, device and hardware version, which can be obtained from the PLC side;

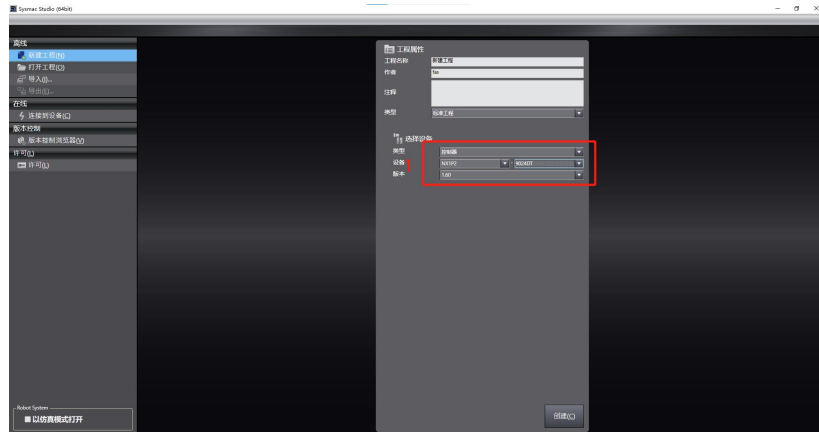

2、 Click on EtherCAT, bring up the main device and right-click to display the drop-down menu and click on Show ESI Library;

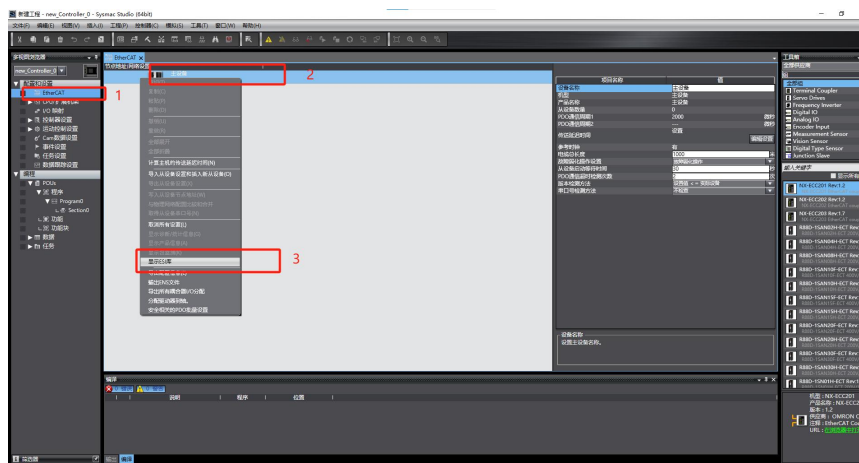

3、 Click on the installation file;

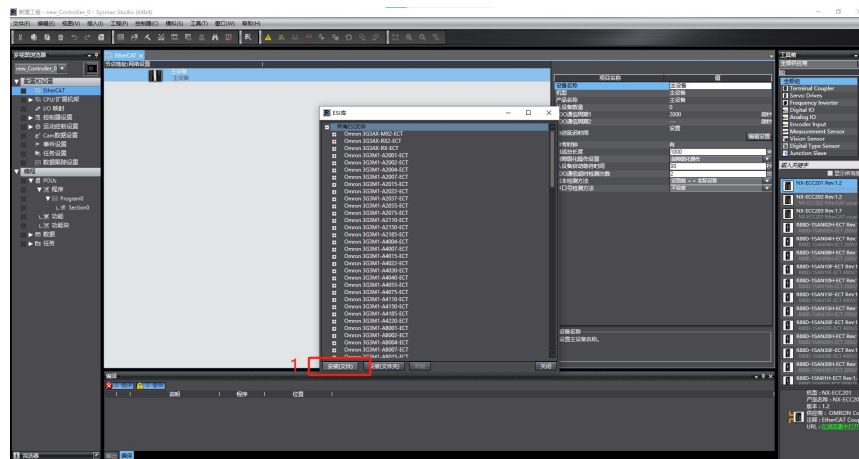

4、Open the ESI configuration file: FAS FNI ECT-xx6-x0x-K54&D64 ECS V5.0.0.xml, which was downloaded in advance from the official website, and confirm it;

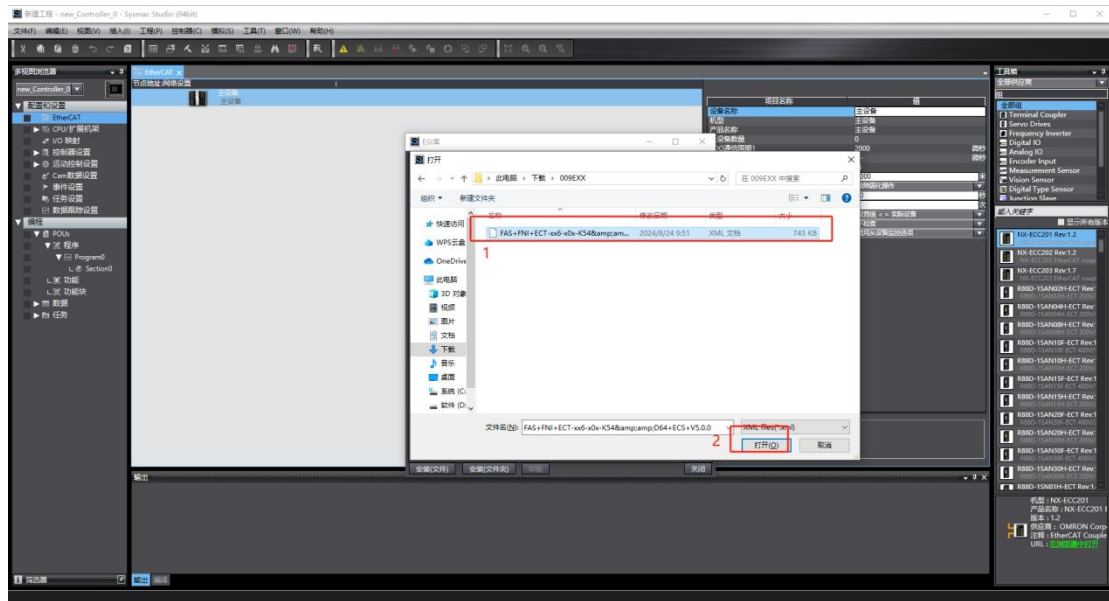

5、Find FAS FieldBus Modules in the toolbox on the right hand side and find the module model icon and double click to add it to the network;

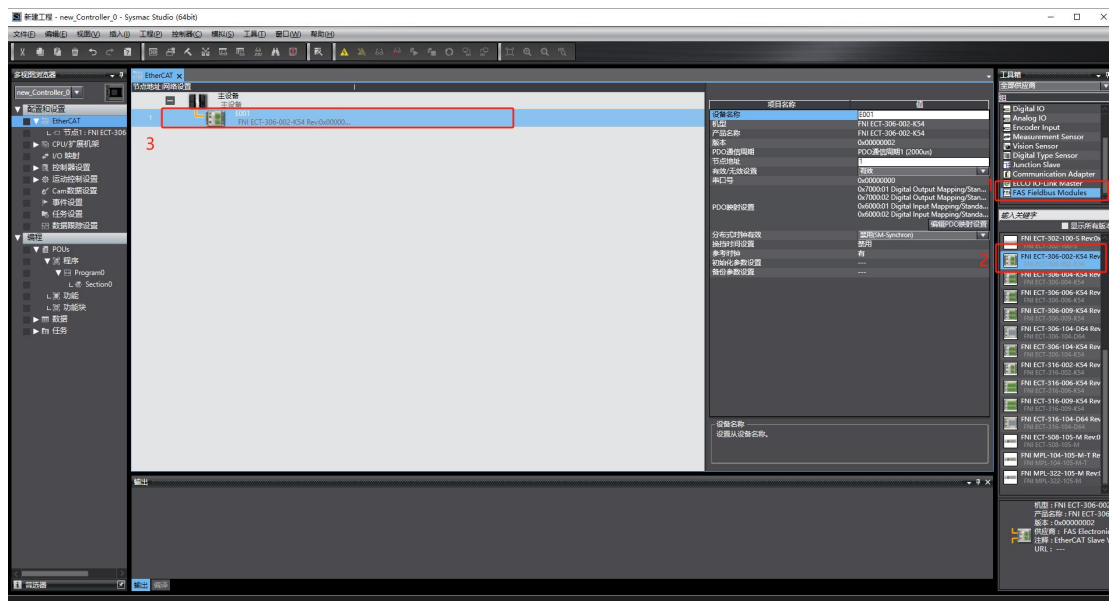

6、Click on IO Variable Mapping, check the added node in I/O Mapping, and fill in the name at Variable

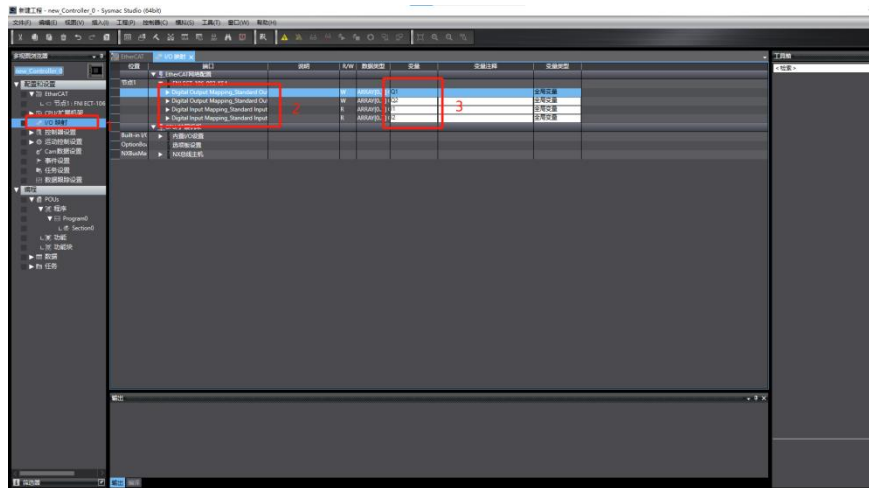

7、Click the PLC online mode button, the configuration interface shows the controller status online and then right-click the master device, write the device node address, note that the node address needs to be consistent with the previous EtherCAT slave device;

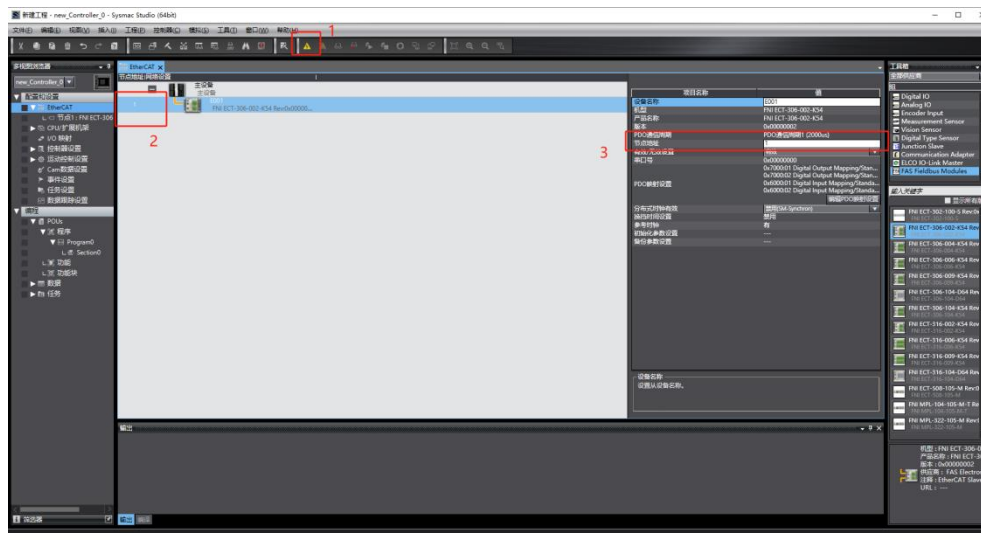

8、Find the controller in the menu bar, transfer to the controller, download to the PLC and agree to the confirmation;

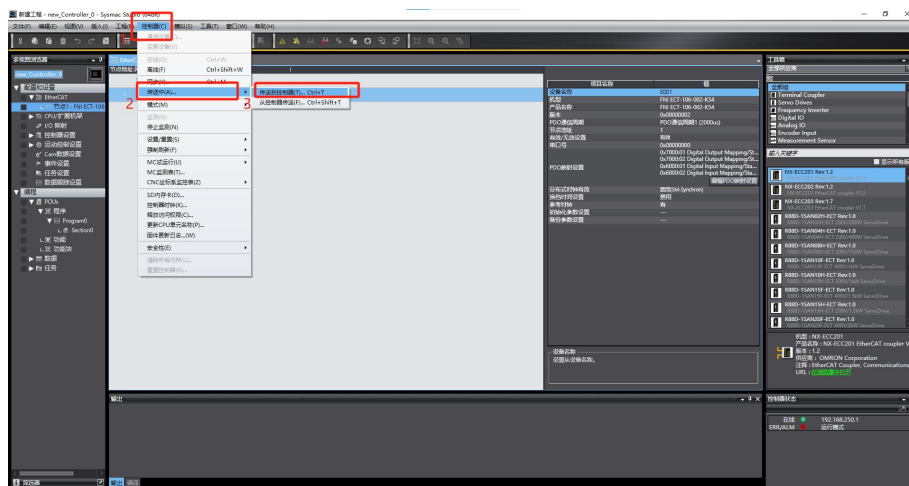

4 Appendix

4.1 Ordering Information

Product Ordering Code	Order Code
FNI ECT-306-002-K54	009E12

High quality products · Sincere service



[Technical support]



[Official website]



Telephone : 0591-22991876

Technical support : +86 13306936805

Official website: www.faselec.com

Business support : +86 19905006938

Address: Room 009, A1, Building 1, National University Science and Technology Park Science and Technology Innovation Center, No. 6 Qiuyang East Road, Shangjie Town, Minhou County, Fujian Province.