



PRODUCT

USE INSTRUCTIONS



[Technical support]

Ordering code: 009E93

Part number: FNI ECT-116-104-D64

EtherCAT IP20 bus module user manual

64 DI/DO PNP adaptive

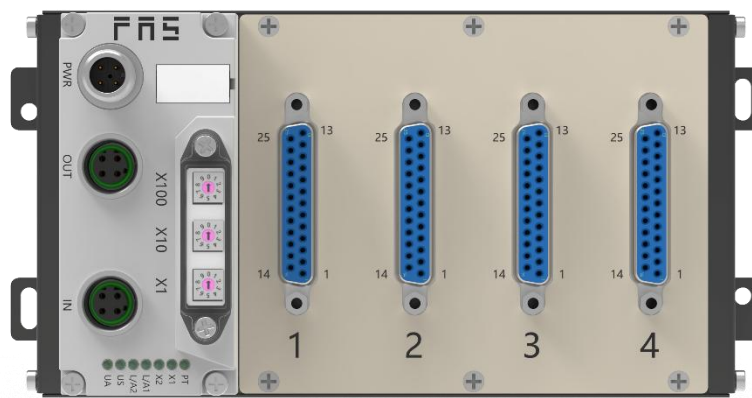

[Contents](#)

Security	4
■ Expected use	4
■ Installation and start-up	4
■ Corrosion resistance	4
■ Dangerous voltage	4
1 Getting started guide	6
1.1 Module overview	6
1.2 Mechanical connection	7
1.3 Electrical connections	7
1.3.1 Power interface (A-coded).....	7
1.3.2 Network interface (D-coded).....	7
1.3.3 Signal port (D-SUB 25, female socket).....	8
1.3.4 Module wiring method	9
2 Technical data	10
2.1 Size	10
2.2 Mechanical data	11
2.3 Operating conditions	11
2.4 Electrical data	11
2.5 Network port.....	11
2.6 Function indicator	12
3 Integrated	13
3.1 Module configuration	13
3.1.1 Reset	13
3.1.2 Node address configuration	13
3.1.3 Data mapping	13
3.2 PLC integration tutorial	13
4 Appendix	17
4.1 Ordering information.....	17

■ Expected use

This manual describes as decentralized input and output modules for connecting to an industrial network.

■ Installation and start-up

Precautions!

Installation and start-up may only be performed by trained personnel. A qualified individual is one who is familiar with the installation and operation of the product and has the necessary qualifications to perform such operations. Any damage caused by unauthorized operation or illegal and improper use is not covered by the manufacturer's warranty. The equipment operator is responsible for ensuring that appropriate safety and accident prevention regulations are observed.

■ Corrosion resistance

Precautions!

FNI modules generally have good chemical and oil resistance. When used in corrosive media (e.g. high concentrations of chemicals, oils, lubricants, coolants and other material media (i.e. very low water content), these media must be checked before the corresponding application material compatibility. If a module fails or is damaged due to this corrosive medium, a defect claim cannot be made.

■ Dangerous voltage

Precautions!

Disconnect all power before using the device!

■ General security

Debugging and inspection	Fault	Owner/operator obligations	Expected use
<p>Before debugging, read the user manual carefully.</p>	<p>If the defect or equipment failure cannot be corrected, the operation of the equipment must be stopped to avoid damage that may be caused by unauthorized use.</p>	<p>This equipment is an EMC Class A compliant product. This device produces RF noise.</p>	<p>The warranty and limited liability statement provided by the manufacturer does not cover damage caused by:</p> <ul style="list-style-type: none"> ·Unauthorized tampering ·Improper use operation <p>·The instructions provided in the user manual explain the use, installation and handling of discrepancies</p>
<p>This system cannot be used in an environment where the safety of personnel depends on the functionality of the equipment.</p>	<p>Only after the housing is fully installed can the intended use be assured.</p>	<p>The owner/operator must take appropriate precautions to use this equipment.</p> <p>This device can only use the power supply that matches this device, and can only connect cables approved for application.</p>	

1. Getting started guide

1.1 Module overview

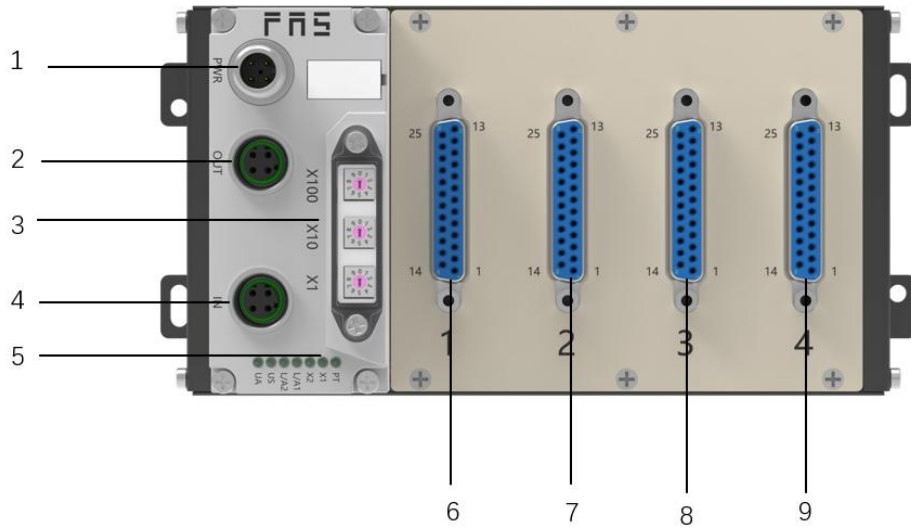

- 1 Power supply interface
- 2 EtherCAT output
- 3 DIP switch
- 4 EtherCAT input port
- 5 Module status indicator light

- 6 Channel 1
- 7 Channel 2
- 8 Channel 3
- 9 Channel 4

1.2 Mechanical connection

The module is installed using 4 M4 bolts or DIN35 rail snaps.

1.3 Electrical connection

1.3.1 Power interface (A-coded)

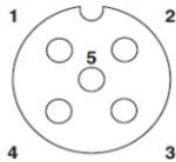

Pin	Function	
1	UA	+24V(Brown)
2	GND	0V(White)
3	Us	+24V (Blue)
4	GND	0V(Black)

Power port

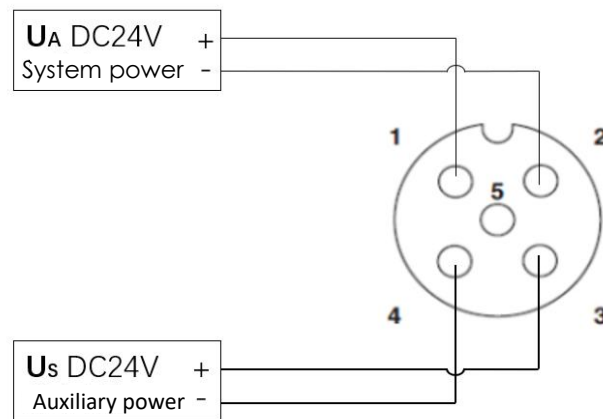

Illustrate:

1. It is recommended to provide Us power supply and UA power supply separately;
2. The total current of UA power supply is <math><4A</math>, and the total current of Us power supply is <math><4A</math>;
3. The FE connection from the housing to the machine must be low impedance and kept as short as possible.

1.3.2 Network interface (D-coded)

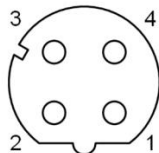

Pin	Function	
1	Tx+	Send data+
2	Rx+	Receive data+
3	Tx-	Send data-
4	Rx-	Receive data-

Illustrate:

Unused I/O port sockets must be covered with end caps to meet IP67 protection rating

1.3.3 Signal port (D-SUB 25, female socket)

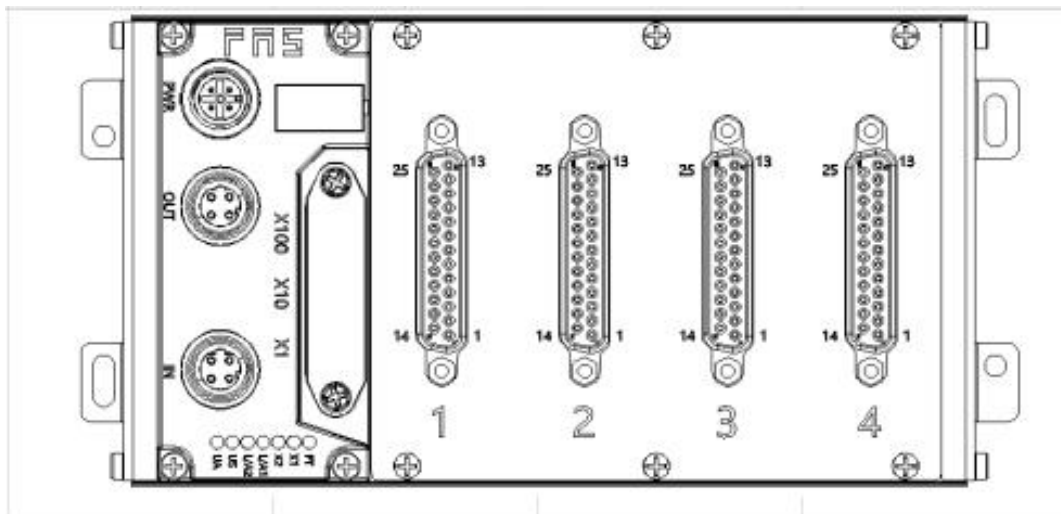

Gate 1		Gate 2		Gate 3		Gate 4	
针	功能	针	功能	针	功能	针	功能
2	CH3	2	CH19	2	CH35	2	CH51
3	CH5	3	CH21	3	CH37	3	CH53
4	CH7	4	CH23	4	CH39	4	CH55
5	CH9	5	CH25	5	CH41	5	CH57
6	CH11	6	CH27	6	CH43	6	CH59
7	CH13	7	CH29	7	CH45	7	CH61
8	CH15	8	CH31	8	CH47	8	CH63
9	None	9	None	9	None	9	None
10	None	10	None	10	None	10	None
11	None	11	None	11	None	11	None
12	24V	12	24V	12	24V	12	24V
13	0V	13	0V	13	0V	13	0V
14	CH2	14	CH18	14	CH34	14	CH50
15	CH4	15	CH20	15	CH36	15	CH52
16	CH6	16	CH22	16	CH38	16	CH54
17	CH8	17	CH24	17	CH40	17	CH56
18	CH10	18	CH26	18	CH42	18	CH58
19	CH12	19	CH28	19	CH44	19	CH60
20	CH14	20	CH30	20	CH46	20	CH62
21	CH16	21	CH32	21	CH48	21	CH64
22	None	22	None	22	None	22	None
23	None	23	None	23	None	23	None
24	24V	24	24V	24	24V	24	24V
25	0V	25	0V	25	0V	25	0V

Illustrate:

Input signal type support: three-wire PNP, two-wire PNP, dry contact;

Pin +24V single output current maximum 350mA. The total module current is <4A;

The total current of each 8 channels does not exceed 1A.

1.3.4 Module wiring method

Independent power supply

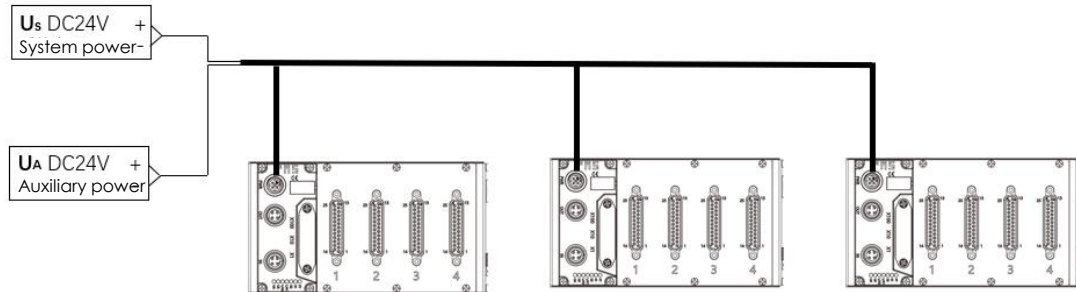

In independent power supply mode, the maximum current of each module can reach 4A.

2. Technical data

2.1 Size

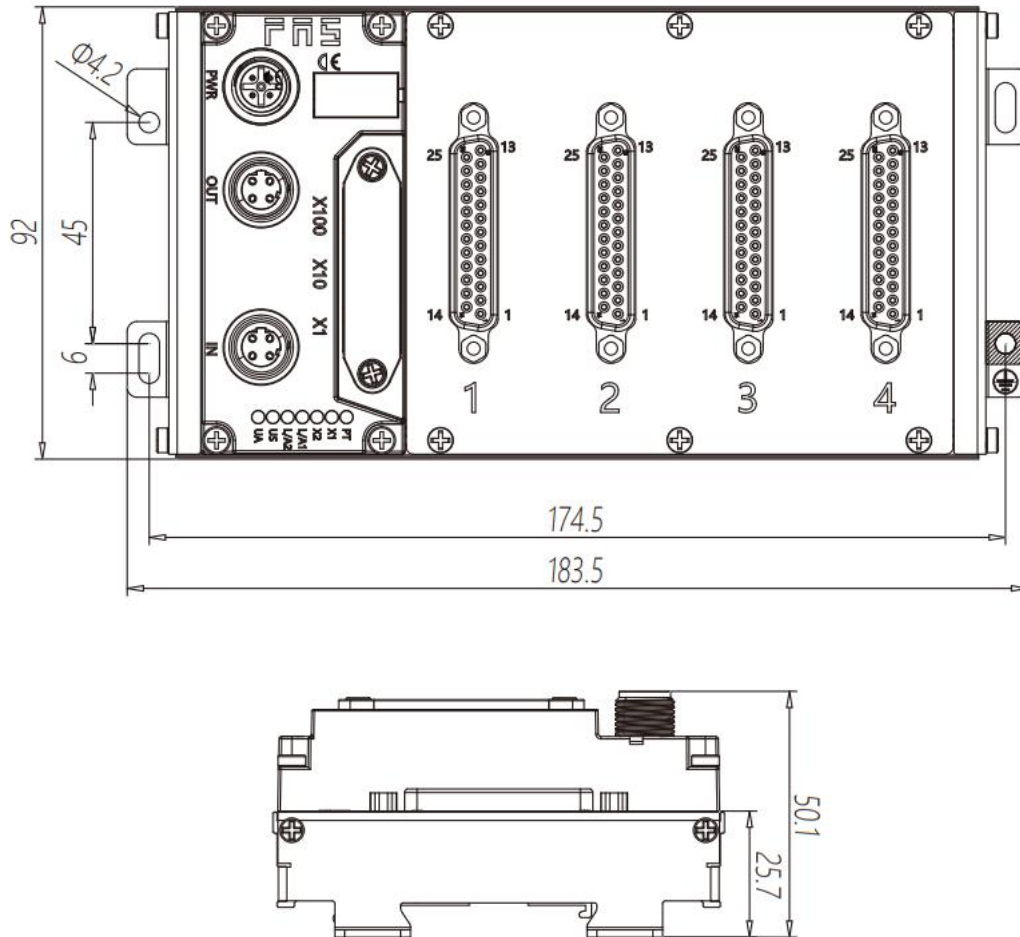

2.2 Mechanical data

Shell material	Aluminum shell
Housing rating according to IEC 60529	IP20
Power interface	A-Coded
Input port/output port	DUSB-25
Size(W*H*D)	183.5mm*92mm*50.1mm
Installation type	Screw fixing or DIN35 rail mounting
Weight	About 670g

2.3 Operating conditions

Operating temperature	-5°C ~ 80°C
Storage temperature	-25°C ~ 85°C

2.4. Electrical data

Voltage	18~30V DC, conform to EN61131-2
Voltage fluctuation	<1%
Input current when power supply voltage is 24V	<130mA
Maximum load current, sensor/channel	1 A
Maximum load current, actuator	0.5A
Total current Us	≤4A
Total current Ua	≤4A

2.5 Network port

Port	2 x 10Base-/100Base-Tx
Port connection	M12, D-Coded
IEEE 802.3 compliant cable types	Shielded twisted pair, minimum STP CAT 5/STP CAT 5e
Data transfer rate	10/100 Mbit/s
Maximum cable length	100m
Flow control	Half working condition/full working condition (IEEE 802.3-PAUSE)

2.6 Function indicator



LED	Show	Function
PT	Blue	EtherCAT protocol
X1	Closure	No error, device initializing
	Green light flashes 2.5HZ	Pre-operation: The device is in pre-operation state
	Green light flashes 1HZ	Safe operation: The equipment is in safe operation.
	Green constant	Running: The device is running
X2	Closure	No errors, device EtherCAT communication is working
	Red light flashes 2.5HZ	Invalid configuration
	Red light flashes 1HZ	local error
	Red light double flash	Application monitoring timeout
L/A1	Steady green	Device (IN) connected to Ethernet
	Yellow light flashes	Device (IN) sends/receives Ethernet frames
	Closure	Device (IN) is not connected to Ethernet
L/A2	Steady green	Device (OUT) connected to Ethernet
	Yellow light flashes	Device (OUT) sends/receives Ethernet frames
	Closure	Device (OUT) is not connected to Ethernet
US	Green	Input voltage is normal
	Flashing red	Input voltage low (< 18 V)
UA	Green	Output voltage is normal
	Flashing red	Output voltage low (< 18 V)
	Red always on	No output voltage present (< 11 V)

3.Integrated

3.1 Module configuration

3.1.1 Restore factory settings

Steps:

1. When the device is powered off, dial 900;
2. Power on the device and wait 10 seconds;
3. Power off the device and dial the code to the state before setting;
4. Power on the device and restore it to factory status;

3.1.2 Node address configuration

- ① The node address is assigned by the PLC: the dialing address X100=4 X10=0 X1=0, the node number is set in the PLC;
- ② Manual allocation of node address: Dial address X100=4, node number is X10=tens digit X1=units digit

Example:

Dial code: X100=4, X10=2, X1=5

The node number is 25

Note that the maximum node number is 99. After dialing adjustment, you need to power on again;

3.1.3 Data mapping

Digital Output Mapping_Standard Output 01-08_3000_01: Channel 1~8 output signal mapping

Digital Output Mapping_Standard Output 09-16_6000_02: Channel 9~16 output signal mapping

Digital Output Mapping_Standard Output 01-08_3000_01: Channel 1~8 output signal mapping

Digital Output Mapping_Standard Output 09-16_6000_02: Channel 9~16 output signal mapping

3.2 PLC integration tutorial

5.3.1 Omron NX1P2 Sysmac Studio integration (ECT)

1. Create a new project and determine the device type, device and hardware version, which can be obtained from the PLC side;

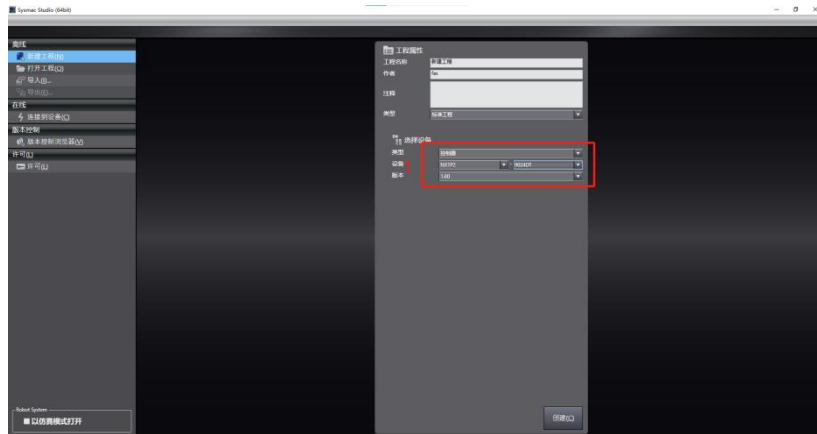

2. Click EtherCAT, pop up the main device and click Show ESI Library in the drop-down menu displayed by right-clicking;

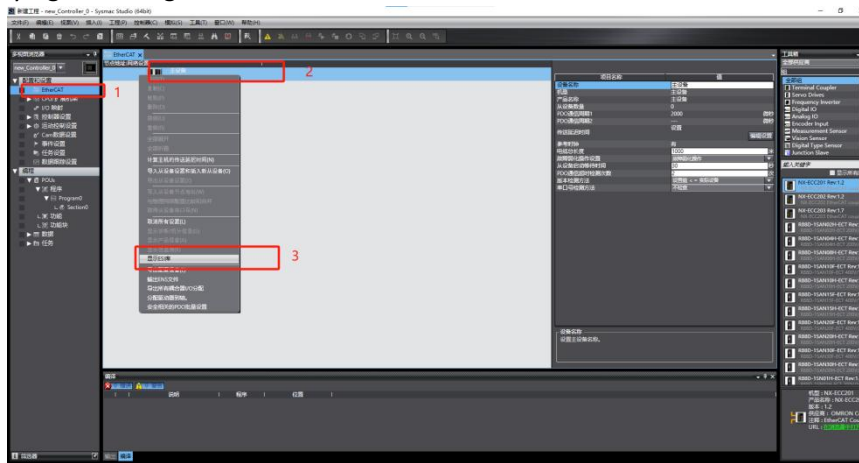

3. Click the installation file;

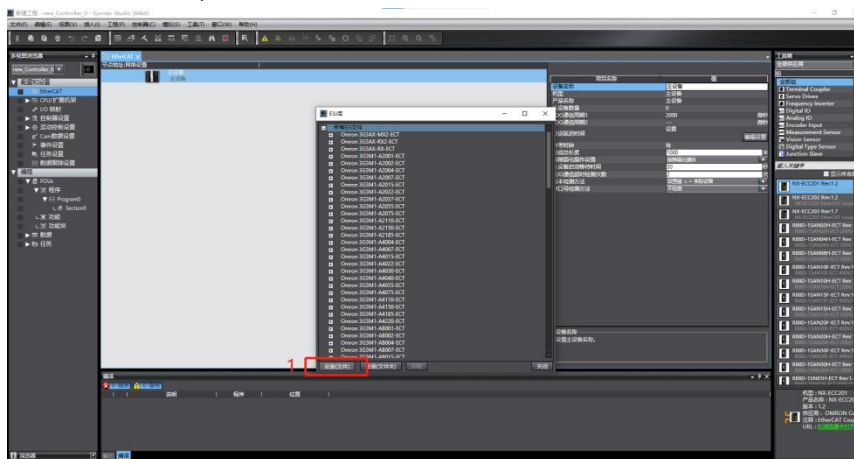

4. Open the ESI configuration file downloaded in advance from the official website: FAS FNI ECT-116-104-D64 ECS V5.0.0.xml, and confirm;

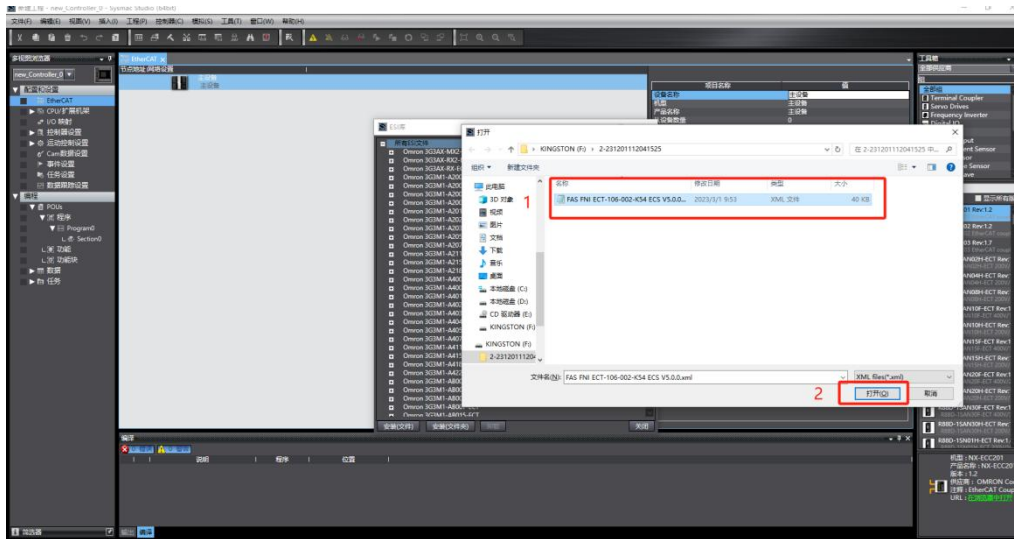

5. Find the FAS FieldBus Modules in the toolbox on the right and double-click the module model icon to join the network;

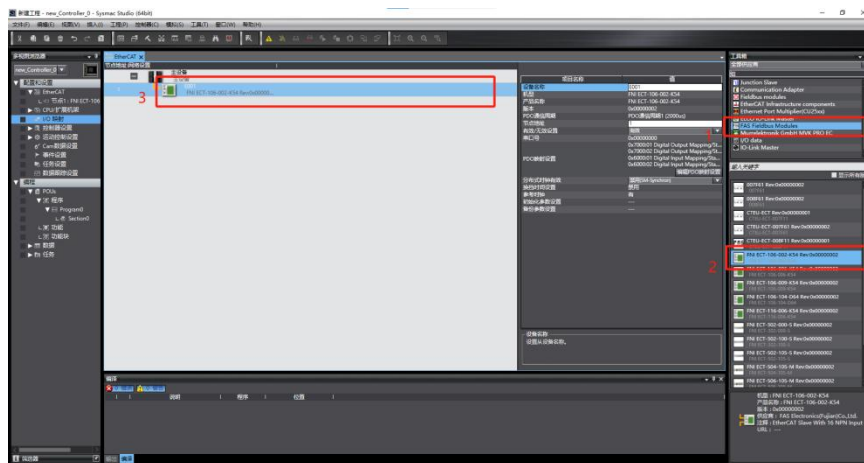

6. Click IO variable mapping, select the added node in the I/O mapping, and fill in the name of the variable

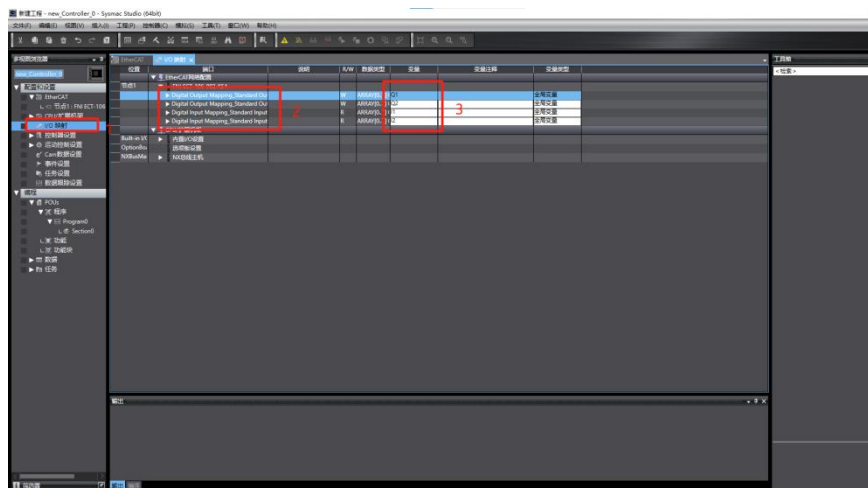

7. Click the PLC online mode button. The configuration interface shows that the controller status is offline. Then right-click the master device and write the device node address. Note that the node address needs to be consistent with the previous EtherCAT slave device;

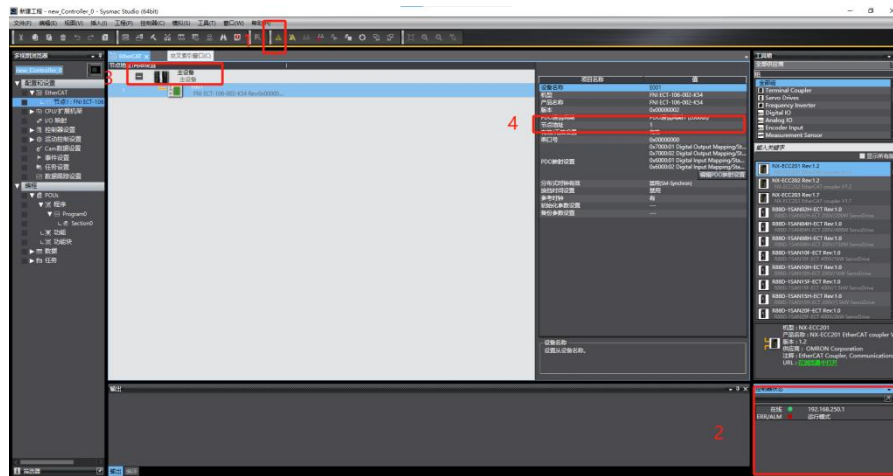

8. Find the controller in the menu bar, transfer it to the controller, download it to the PLC, and agree to confirm;

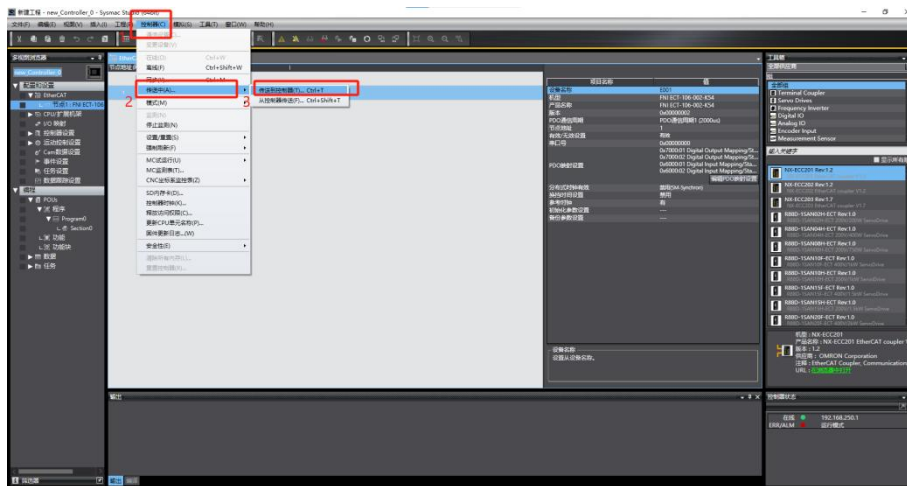

9. PLC is online, the output terminal value is set to 1, the value displays TRUE and turns orange, and the corresponding signal light of the slave device lights up.

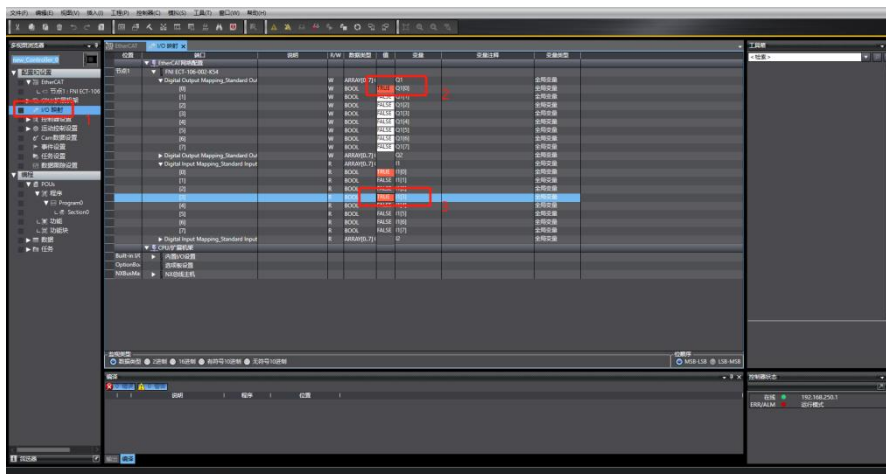

4. Appendix

4.1 Ordering information

Product ordering code	Ordering code
FNI ECT-116-104-D64	009E93

High quality products · Sincere service



[Technical support]



[Official website]



Telephone : 0591-22991876

Technical support : +86 13306936805

Official website: www.faselec.com

Business support : +86 19905006938

Address: Room 009, A1, Building 1, National University Science and Technology
Park Science and Technology Innovation Center, No. 6 Qiuyang East Road,
Shangjie Town, Minhou County, Fujian Province.